

Smart choice for power

xantrex

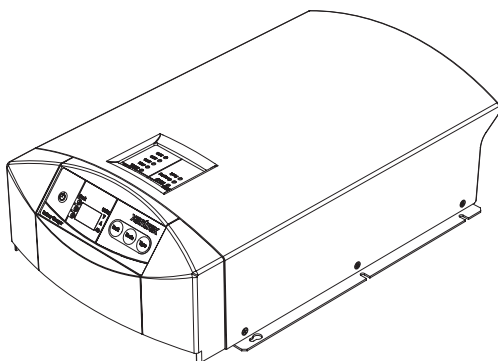

Solarlink GmbH
Drangstedter Str. 37
D 27624 Bad Bederkesa

GERMANY

mail: info@solarlink.de
web: www.solarlink.de

Owner's Guide

Xantrex
XC3012, XC5012,
XC1524 and XC2524
Battery Charger

12 V / 30 A
12 V / 50 A
24 V / 15 A
24 V / 25 A

www.xantrex.com

Xantrex XC3012, XC5012, XC1524 and XC2524 Battery Charger

Owner's Guide

About Xantrex

Xantrex Technology Inc. is a world-leading supplier of advanced power electronics and controls with products from 50 watt mobile units to one MW utility-scale systems for wind, solar, batteries, fuel cells, microturbines, and backup power applications in both grid-connected and stand-alone systems. Xantrex products include inverters, battery chargers, programmable power supplies, and variable speed drives that convert, supply, control, clean, and distribute electrical power.

Trademarks

Xantrex XC3012, XC5012, XC1524 and XC2524 Battery Charger is a trademark of Xantrex International. Xantrex is a registered trademark of Xantrex International.

Other trademarks, registered trademarks, and product names are the property of their respective owners and are used herein for identification purposes only.

Notice of Copyright

Xantrex XC3012, XC5012, XC1524 and XC2524 Battery Charger Owner's Guide© August 2005
Xantrex International. All rights reserved.

Disclaimer

UNLESS SPECIFICALLY AGREED TO IN WRITING, XANTREX TECHNOLOGY INC.
("XANTREX")

(a) MAKES NO WARRANTY AS TO THE ACCURACY, SUFFICIENCY OR SUITABILITY OF ANY TECHNICAL OR OTHER INFORMATION PROVIDED IN ITS MANUALS OR OTHER DOCUMENTATION.

(b) ASSUMES NO RESPONSIBILITY OR LIABILITY FOR LOSS OR DAMAGE, WHETHER DIRECT, INDIRECT, CONSEQUENTIAL OR INCIDENTAL, WHICH MIGHT ARISE OUT OF THE USE OF SUCH INFORMATION. THE USE OF ANY SUCH INFORMATION WILL BE ENTIRELY AT THE USER'S RISK.

Date and Revision

August 2005 Revision B

Part Number

975-0187-01-01

Contact Information

Phone: 1 800 670 0707 (toll free North America)
+34 93 470 5330 (Europe)
1 360 925 5097 (direct and rest of world)

Fax: 1-800 994 7828 (toll free North America)
+34 93 473 6093 (Europe)
1 360 925 5143 (direct and rest of world)

Email: customerservice@xantrex.com (North America)
support.europe@xantrex.com (Europe)
customerservice@xantrex.com (rest of world)

Web: www.xantrex.com

About This Guide

Purpose

The purpose of this Owner's Guide is to provide explanations and procedures for installing, operating, maintaining, and troubleshooting the Xantrex XC3012, XC5012, XC1524 and XC2524 Battery Charger.

Scope

The Guide provides safety guidelines, detailed planning and setup information, procedures for installing the charger, as well as information about operating and troubleshooting the unit. It does not provide details about particular brands of batteries. Consult individual battery manufacturers for this information.

Audience

The Guide is intended for anyone who needs to install and operate the Xantrex XC3012, XC5012, XC1524 and XC2524 Battery Charger. Installers should be certified technicians or electricians.

Organization

This Guide is organized into 4 chapters and 1 appendix:

Chapter 1, "Introduction": Chapter 1 describes the XC Series standard features. It also provides information to prepare for installation of the XC Series.

Chapter 2, "Installation": Chapter 2 provides procedures for installing, testing and configuring the XC Series.

Chapter 3, "Operation": Chapter 3 describes the operating states and provides procedures for charging a battery and performing an equalization.

Chapter 4, "Troubleshooting": Chapter 4 contains information on error codes and procedures for troubleshooting your XC Series charger.

Appendix A, "Specifications": Appendix A details the specifications for the XC Series.

Conventions Used

The following conventions are used in this guide.



WARNING

Warnings identify conditions or practices that could result in personal injury or loss of life



CAUTION

Cautions identify conditions or practices that could result in damage to the unit or other equipment.

Important: These notes describe things which are important for you to know, but not as serious as a caution or warning.

This Guide contains information for four versions of the XC Series.

The Xantrex XC3012 Battery Charger (12 V, 30 A) will be referred to as the XC3012 when it is being referenced individually.

The Xantrex XC5012 Battery Charger (12 V, 50 A) will be referred to as the XC5012 when it is being referenced individually.

The Xantrex XC1524 Battery Charger (24 V, 15 A) will be referred to as the XC1524 when it is being referenced individually.

The Xantrex XC2524 Battery Charger (24 V, 25 A) will be referred to as the XC2524 when it is being referenced individually.

When the Xantrex XC3012, XC5012, XC1524 and XC2524 Battery Chargers are being referenced together, they will be referred to as the XC Series.

Related Information

You can find more information about Xantrex Technology Inc. as well as its products and services at www.xantrex.com

Important Safety Instructions



WARNING

This chapter contains important safety and operating instructions as prescribed by safety standards for chargers used in RV and marine applications. Read and keep this Owner's Guide for future reference.

1. Before installing or using the Xantrex XC3012, XC5012, XC1524 or XC2524 Battery Charger (XC Series), read all instructions and cautionary markings on the XC Series, the batteries, and all appropriate sections of this guide.
2. Do not expose the XC Series to rain, snow, spray, or bilge water. To reduce risk of fire hazard, do not cover or obstruct the ventilation openings. Do not install the XC Series in a zero-clearance compartment. Overheating may result.
3. Use only attachments recommended or sold by Xantrex. Doing otherwise may result in a risk of fire, electric shock, or injury to persons.
4. The XC Series is designed to be permanently connected to the AC and DC electrical systems. Xantrex recommends that all wiring be done by a certified technician or electrician to ensure compliance with the local and national electrical codes relevant to your installation. It is the responsibility of the installer to ensure that the installation of the XC Series complies with all relevant electrical codes.
5. To avoid a risk of fire and electric shock, make sure that existing wiring is in good condition and that wire is not undersized. Do not operate the XC Series with damaged or substandard wiring.
6. Do not disassemble the XC Series. It contains no user-serviceable parts. Attempting to service the XC Series yourself may result in a risk of electrical shock or fire.
NOTE: Disassembling the XC Series will void your warranty.
7. To reduce the risk of electrical shock, disconnect both AC and DC power from the XC Series before attempting any maintenance or cleaning or before working on any circuits connected to the XC Series. Turning the XC Series off using the remote display will not reduce this risk.

8. The XC Series is provided with an AC ground conductor that must be connected to the AC input ground and a DC ground stud which must be connected to the DC system ground.
9. For marine applications in the United States, external connections to the charger shall comply with the United States Coast Guard Electrical Regulations (33CFR183, Sub part 1).

Explosive Gas and Battery Precautions



WARNING: Explosion or fire hazard

1. Read this guide and follow the instructions exactly before installing or using your XC Series.
2. Follow all instructions published by the battery manufacturer and the manufacturer of the equipment in which the battery is installed.
3. Working in the vicinity of lead-acid batteries is dangerous. Batteries generate explosive gases during normal operation.
4. The XC Series has been approved as Ignition Protected. It may be installed in areas containing gasoline tanks and fittings which require Ignition Protected equipment. Xantrex recommends, nevertheless, that it is safest not to install electrical equipment in these areas.
5. Make sure the area around the battery is well ventilated.
6. Never smoke or allow a spark or flame near the engine or batteries.
7. Use caution to reduce the risk of dropping a metal tool on the battery. It could spark or short circuit the battery or other electrical parts and could cause an explosion.
8. Remove all metal items, like rings, bracelets, and watches when working with lead-acid batteries. Lead-acid batteries produce a short circuit current high enough to weld metal, causing a severe skin burn.
9. Have someone within range of your voice or close enough to come to your aid when you work near a lead-acid battery.

10. Have plenty of fresh water and soap nearby in case battery acid contacts skin, clothing, or eyes.
11. Wear complete eye protection and clothing protection. Avoid touching your eyes while working near batteries.
12. If battery acid contacts skin or clothing, wash immediately with soap and water. If acid enters your eye, immediately flood it with running cold water for at least twenty minutes and get medical attention immediately.
13. If you need to remove a battery, always remove the ground terminal from the battery first. Make sure all accessories are off to reduce the possibility of causing a spark.

FCC Information

This equipment has been tested and found to comply with the limits for a Class B digital device, pursuant to part 15 of the FCC Rules. These limits are designed to provide reasonable protection against harmful interference in a residential installation. This equipment generates, uses, and can radiate radio frequency energy and, if not installed and used in accordance with the instructions, may cause harmful interference to radio communications.

However, there is no guarantee that interference will not occur in a particular installation. If this equipment does cause harmful interference to radio or television reception, which can be determined by turning the equipment off and on, the user is encouraged to try to correct the interference by one or more of the following measures:

- Reorient or relocate the receiving antenna.
- Increase the separation between the equipment and receiver.
- Connect the equipment into an outlet on a circuit different from that to which the receiver is connected.
- Consult the dealer or an experienced radio/TV technician for help.

Contents

Important Safety Instructions

Explosive Gas and Battery Precautions	vi
FCC Information	vii

1 Introduction

Xantrex XC3012, XC5012, XC1524 and XC2524 Battery Charger Features	1-2
XC Series Appearance	1-3
Information Centers of the XC Series	1-4
Remote Display	1-4
Onboard Status Panel	1-6
Rear Panel	1-7
Preparing for Installation	1-8
Tools and Materials	1-9
Location	1-10
Wiring Requirements	1-12
DC Wiring	1-12
AC Wiring	1-13
Battery Bank Size Requirements	1-14

2 Installation

Installing the XC Series	2-2
Installation Sequence	2-2
Pre-Installing DC Wiring	2-3
Pre-Installing AC Wiring	2-4
Mounting the Remote Display	2-7
Mounting	2-8
Grounding	2-9
Final Connections	2-10
Final DC Connections	2-11
Final AC Connections	2-12
Powering Up	2-12

Installing Optional Accessories----- 2-13
 Battery Temperature Sensor ----- 2-13
 Drip Protection Rubber Boots ----- 2-14
Configuring the XC Series----- 2-15

3 Operation

About Charging ----- 3-2
 Multiplex 3-Stage Charging ----- 3-2
 Sequential 2-Stage Charging ----- 3-3
 Charging Overview ----- 3-3
Charging Batteries ----- 3-6
Equalizing Flooded Batteries ----- 3-8
Transitioning the XC Series to On, Disabled or Off ----- 3-10
Accessing Charger Information ----- 3-11
 Reading Remote Display and Onboard Status Indicator Lights ----- 3-11
 Reporting While Charging or Equalizing ----- 3-13
 Reporting While Battery Monitoring ----- 3-14
 Reporting While Disabled ----- 3-14
 Using A Generator As Source Power ----- 3-15

4 Troubleshooting

Care and Maintenance----- 4-2
Indicator Light Flashing Sequences----- 4-3
Error Messages on Remote Display----- 4-4
Problem Solving ----- 4-7

A Specifications

Physical Specifications ----- A-2
Electrical Specifications ----- A-2
AC Input Specifications ----- A-3
Temperature Specifications ----- A-4
Protection Features ----- A-4
Approvals ----- A-5

Warranty and Product Information----- WA-1

1

Introduction

Chapter 1 describes the XC Series standard features. It also provides information to prepare for installation of the XC Series.

Xantrex XC3012, XC5012, XC1524 and XC2524 Battery Charger Features

The XC Series provides the following standard features:

- three full current rated, independently controlled outputs which enable it to charge three different batteries or battery banks. Each bank can be of a different battery type, stage of charging, and temperature compensation
- one battery temperature sensor (BTS) is included. Optional BTSs may be purchased for the other two outputs, to provide complete optimal battery charging to each battery or bank
- battery monitoring functions while in float mode or rest mode
- correct charging voltage for your batteries when connected to almost any single phase AC power outlet in the world
- invertable remote display panel which can also be removed from the charger and mounted up to 20 m (65 ft) away for remote control and monitoring

The XC Series provides the following protection features:

- true “fuseless” reverse polarity protection to guard against continuous reverse battery polarity without charger damage
- AC over voltage protection shutdown
- over temperature protection shutdown
- electronic current limiting for protection against short circuit on the unit’s output
- built-in protection against accidental connection to a higher battery voltage, up to 24 VDC
- battery temperature compensation to 0 °C (32 °F) (with BTS installed)
- ignition protected rating, enabling installation in engine spaces
- isolated design to reduce shock hazard
- automatic charge resumption after AC power interruption

XC Series Appearance

This section describes the parts of the XC Series. Figure 1-2 shows the XC Series.

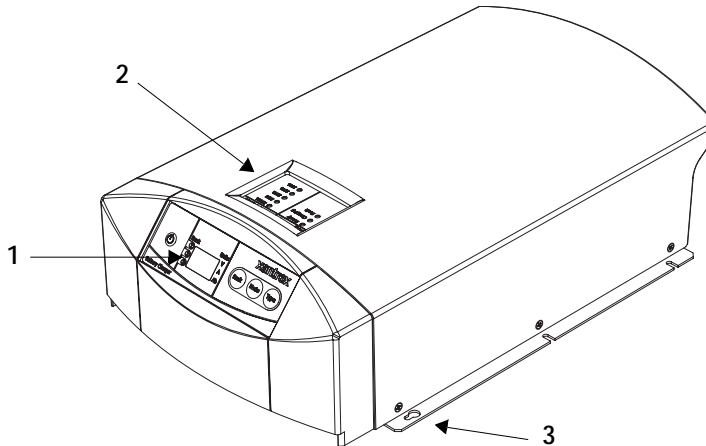

Figure 1-1 XC Series

Item	Description
1	Remote display for all programming functions and monitoring of the XC Series.
2	Onboard status panel for monitoring charger status and charging current at the XC Series when the remote display is mounted remotely from the charger.
3	Mounting flanges

Information Centers of the XC Series

Remote Display

This section describes the parts of the remote display of the XC Series. The remote display can be rotated 180°, or it can be removed and remotely mounted up to 20 m (65 ft) from the XC Series for convenience. Figure 1-2 shows the remote display.

A “press and hold” action on the remote display means that the button must be held down for more than 2 seconds in order to send the instruction. A “press” action on the remote display means that the button must be pressed and released before 2 seconds have elapsed.

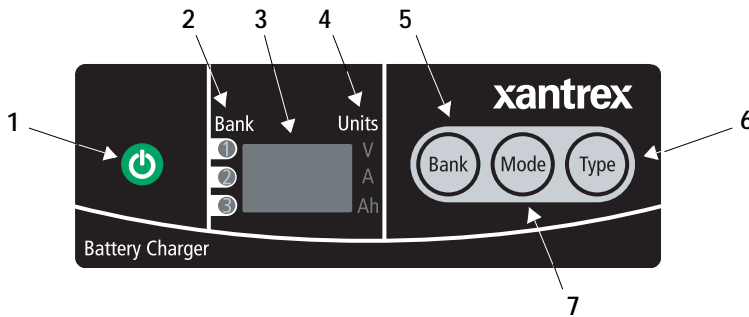

Figure 1-2 XC Series Remote Display

Item	Description
1	ON/STANDBY push button <ul style="list-style-type: none"> • Press to turn on or disable the charger while AC power is connected • Press and hold to apply selection when in setup or equalization mode • Press to show battery bank voltages when AC is disconnected
2	Battery bank indicator lights <ul style="list-style-type: none"> • Illuminate to show which bank has been selected for setup or status display • Illuminate during a fault or warning to show which bank has the fault or warning, or illuminate all three if the charger itself has the fault or warning

Item	Description
3	Alpha-numeric display shows <ul style="list-style-type: none">• Configuration• Fault or warning messages (see Table 4-2 on page 4-4)• Battery bank voltage and current• Type of charging (2 stage or 3 stage)• State of charge
4	Units indicator lights <ul style="list-style-type: none">• Illuminate to show unit of measure for the numeric read-out on the alpha-numeric display
5	BANK selection push button <ul style="list-style-type: none">• Press to select a bank during setup• Press at the same time as MODE to enter or exit equalization mode.
6	TYPE selection push button <ul style="list-style-type: none">• Press to select flooded (lead acid), gel, AGM, or lead calcium batteries.
7	MODE selection push button <ul style="list-style-type: none">• Press to select charging state during setup: 2 stage or 3 stage.• Press at the same time as BANK to enter or exit equalization mode.• Press and hold to enter setup.

The indicator lights and display are also used to indicate error codes. See Chapter 4, “Troubleshooting” for a list of faults and how to clear them.

Onboard Status Panel

This section describes the parts of the onboard status panel of the XC Series. Figure 1-3 shows the panel.

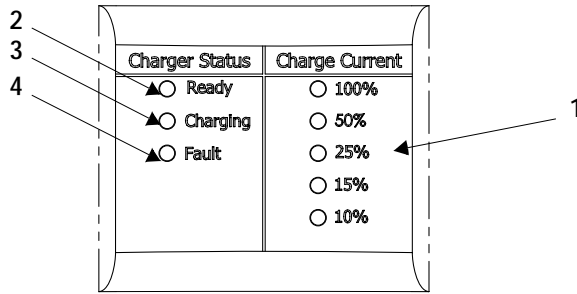

Figure 1-3 XC Series Onboard Status Panel

Item	Description
1	<p>Charge Current</p> <ul style="list-style-type: none"> Displays the output charge current in % of charger maximum for the bank being charged 100% indicator light flashes to indicate battery temperature too high (> 50 °C, 122 °F) 10% indicator light flashes to indicate battery temperature too low (< 0 °C, 32 °F) 25% indicator light flashes to indicate that a battery has been disqualified (see page 3–4)
2	<p>Charger Status - READY</p> <ul style="list-style-type: none"> Ready indicator light illuminated indicates all batteries are fully charged, and are now in float or rest
3	<p>Charger Status - CHARGING</p> <ul style="list-style-type: none"> Charging indicator light illuminated indicates unit is performing a normal charge cycle Charging indicator light flashing indicates that the unit is performing an equalization cycle
4	<p>Charger Status - FAULT</p> <ul style="list-style-type: none"> Fault indicator light continuously illuminated indicates any fault condition that prevents the XC Series from charging one or more batteries, but is not a charger failure - remote display shows details of fault Fault indicator light flashing indicates the XC Series has experienced a charger failure - remote display shows <i>Err</i> followed by <i>LHF</i>

Rear Panel

This section describes the parts of the rear panel of the XC Series. Figure 1-4 shows the rear panel.

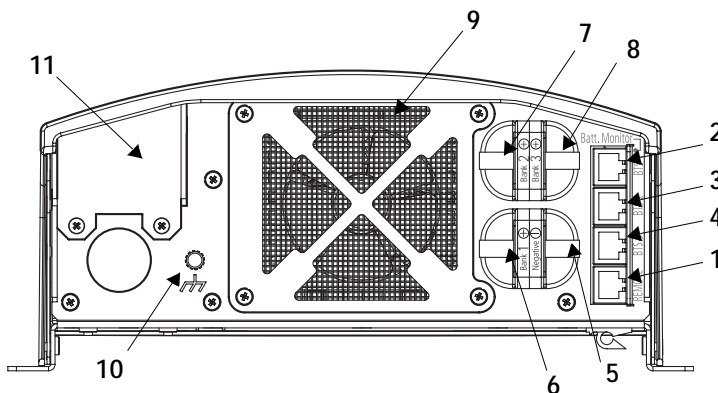

Figure 1-4 XC Series Rear Panel

Item	Description
1	Remote display communication connector
2	BTS1 (battery temperature sensor for bank 1) connector
3	BTS2 (battery temperature sensor for bank 2) connector
4	BTS3 (battery temperature sensor for bank 3) connector
5	Battery negative, common for all 3 banks (6 mm stud)
6	Battery positive for bank 1 (6 mm stud)
7	Battery positive for bank 2 (6 mm stud)
8	Battery positive for bank 3 (6 mm stud)
9	Fan assembly
10	Chassis ground (earth) for DC wiring
11	AC wiring access panel

Preparing for Installation

The XC Series is designed to be permanently mounted. Figure 1-1 shows a typical installation with three batteries, a BTS and a remote display. It also shows the AC and DC wiring and protection devices required for a successful installation.

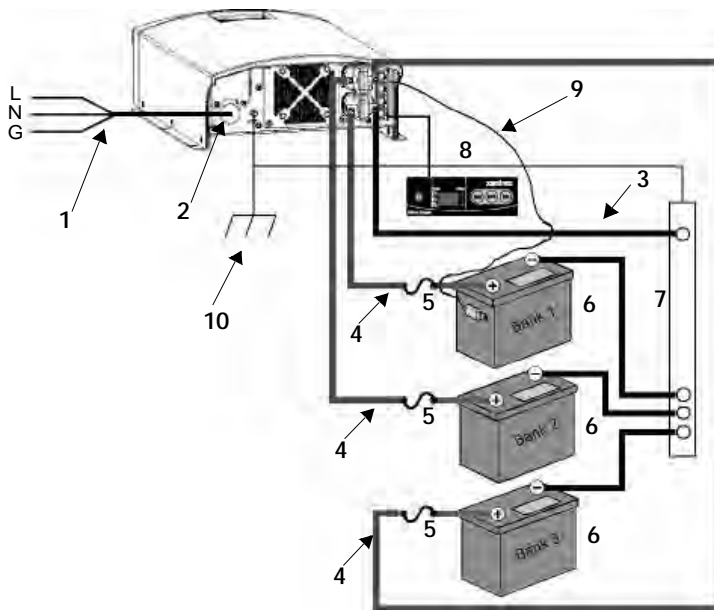

Figure 1-5 XC Series System

1	AC mains source with correct size and type of circuit breaker
2	AC input wiring compartment
3	DC negative cable
4	DC positive cables
5	DC circuit breaker or DC fuse and disconnect
6	Battery or battery bank
7	Engine ground bus or DC negative bus
8	Remote display panel
9	Battery temperature sensor (#1 is standard equipment. #2 and #3 are optional)
10	DC chassis ground (earth)

Tools and Materials

To mount and connect the XC Series you need the following tools:

- 10 mm wrench or socket for the DC terminals and ground stud
- Phillips screwdriver for securing the AC wiring compartment cover
- power drill
- drill bit for pilot holes for mounting screws
- wire stripper
- manufacturer's recommended crimp tool for any crimp terminals that are being used

You need the following materials:

- 3 conductor AC input wiring
Use the information in “AC Wiring” on page 1–13 and your local electrical codes to determine the correct wire and breaker or fuse.
- AC cable strain relief (if the one included is not sufficient for your local electrical code requirements)
- appropriately sized DC cables for each battery, with suitable connectors at the battery end
- appropriately sized DC chassis ground (earth) with suitable connectors
- ring terminals to fit 6 mm (1/4 in.) studs at the charger end
- DC fuse and disconnect or circuit breaker for each battery bank
- mounting hardware, 3 mm (#6) corrosion resistant 6 pieces.
- other means to route and secure AC and DC wiring

Location

Install the XC Series in a location that meets the following requirements:

Condition	Requirement
Dry	The XC Series must be installed in a dry location not subject to rain, spray or splashing bilge water.
Clean	The XC Series should not be exposed to metal filings or any other form of conductive contamination.
Cool	The ambient air temperature should be between 0 °C - 50 °C (32 °F - 122 °F) for best performance.
Ventilated	There must be at least 76 mm (3 in.) of clearance on each end of the XC Series for air flow. Ventilation openings on the unit must not be obstructed. If mounting in a tight fitting compartment, the compartment must be ventilated with cut-outs to prevent overheating.
Safe	This battery charger is ignition protected, so it can be installed in areas containing gasoline tanks or fittings which usually require ignition protected equipment. Xantrex recommends, however, that it is safest not to install electrical equipment in these areas.
Close to batteries	The XC Series should be installed as close as possible to the batteries, but not in the same compartment to prevent excess corrosion. Avoid excessive cable lengths and use the recommended wire sizes. Xantrex recommends <3% wire voltage drop (round circuit) on battery cables under full load.

When planning where and how to mount the XC Series, be sure the installation allows the charger to be mounted in one of the permitted vertical or horizontal orientations.

For marine installations, only the mounting configurations with a check mark in Figure 1-6 meet the North American and European marine requirements. Marine products are required to meet drip tests, to ensure safety in the presence of condensation. If you are certain your installation is not subject to moisture, configuration d) in Figure 1-6 may be used.

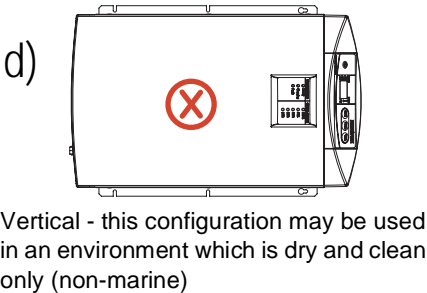
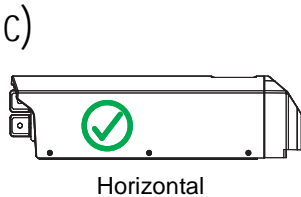
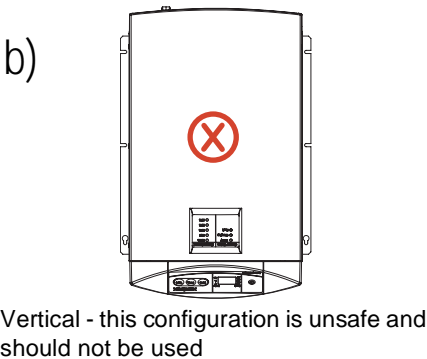
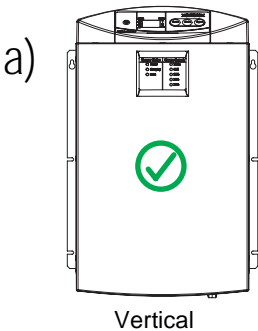

Figure 1-6 XC Series Mounting Orientations

Wiring Requirements



WARNING

Wire and fuse sizes are dictated by electrical standards. Different standards apply in different countries and different types of installations, for example, boat, home or RV. It is the responsibility of the installer to ensure that the installation complies with all applicable standards.



CAUTION

Ensure that both wires and fuses are correctly sized. Maximum continuous current available from the charger may be an additional 6–10% above the nominal current rating of the charger. Output current may also vary depending on ambient temperature conditions.

DC Wiring

The following two tables show some typical wire sizes, based on 3% voltage drop (round circuit), 75 °C (167 °F) rated wire and wiring being inside the engine compartment – assumed ambient of 50 °C (122 °F).

Table 1-1 DC Wiring Requirements

Wire Length (maximum length one way)		Wire Size (AWG and mm ²)			
feet	meters	XC3012	XC5012	XC2524	XC1524
5	1.5	No. 10 5 mm ²	No. 6 13 mm ²	No. 10 5 mm ²	No. 12 3 mm ²
7.5	2.25	No. 8 8 mm ²	No. 6 13 mm ²	No. 10 5 mm ²	No. 12 3 mm ²
20	6	No. 6 13 mm ²	No. 4 19 mm ²	No. 10 5 mm ²	No. 12 3 mm ²

Over-current protection disconnect

The DC circuit from the battery to the charger must be equipped with a disconnect and over-current protection device. The device usually consists of a DC-rated circuit breaker, a “fused disconnect”, or a separate fuse and disconnect. These devices must be rated for DC voltage and current. Do not substitute devices rated only for AC voltage; they may not operate properly.

The current rating of the DC fuses must be matched to the size of the DC wiring used, in accordance with the applicable codes.

The DC chassis ground (earth) should not be more than one size smaller than the DC wiring size selected (see Table 1-1). Refer to your local electrical codes for verification.

AC Wiring

The AC wiring must meet the following requirements before you install the XC Series:

The AC input wiring for the XC Series should be three-conductor cable, providing a line, neutral, and ground conductor (or L1, N, GND) in an outer jacket.

For example, in North America for 120 VAC use a 14 AWG wire with a 15 A breaker; or typically in Europe for 230 VAC use either a 2.5mm² wire with a 16 A, double pole breaker or fuse or use 1.5 mm² wire with a 10 A, double pole breaker or fuse. Note that every jurisdiction will have different requirements, so see the regulations for your local jurisdiction to determine which wire size and type is correct. A second example:

- for marine applications the United States ABYC requires stranded wire, which is more robust than solid wire when exposed to vibration
- for RV applications, the United States NEC allows solid wire in multi-conductor cable, but stranded wire will withstand vibration better.

The circuit supplying the XC Series must be protected by the correct size and type of breaker to meet the code for your local jurisdiction and application. If a fuse is used, a disconnect switch is needed ahead of the fuse.

Battery Bank Size Requirements

The XC Series is designed to work with a minimum battery bank size. Each bank should meet the minimum Ah rating shown in Table 1-2.

Table 1-2 Minimum Battery Bank Size

Models	XC 1524	XC 2524	XC 3012	XC 5012
Minimum Battery Bank Size (Ah)	30	50	60	100

2

Installation

Chapter 2 provides procedures for installing, testing and configuring the XC Series.

The unit is packed with the following materials:

- Owner's Guide
- AC cable strain relief
- Two DC cable boots
- Blank plate for remote display cavity
- One battery temperature sensor (BTS)
- Five #6 lockwashers
- Five #6 flatwashers
- Five #6 nuts

After unpacking the unit, record the serial number and other purchase information on page WA-4 of this guide.

Installing the XC Series



WARNING: Shock and Energy Hazards

Be sure to read the safety guidelines and pay attention to all cautions and warnings throughout the installation procedure. The installer is responsible for ensuring compliance with the installation codes for your particular application.

Disconnect all sources of AC and DC power before proceeding.

Installation Sequence

To make charger installation quick and easy, Xantrex recommends that the installation tasks be performed in the following sequence:

1. Select charger mounting position and plan AC and DC cable routing (page 1–8)
2. Install DC cable runs and fuses or breakers (page 2–3)
3. Make the AC connections at the charger (page 2–4)
4. Mount the remote display and charger in position (page 2–7)
5. Make the final DC and then AC cable connections (including earth grounds) (page 2–10)

Pre-Installing DC Wiring

The procedure for installing the DC wiring applies to a single battery or multiple batteries or battery banks.



WARNING: Shock or arc burn hazard

To help prevent accidental shorts or sparks, leave the DC disconnects or breakers in the Off position or fuses removed from their fuse holders until installation is complete.

Important: Xantrex recommends that you install the rubber boots over the XC Series DC terminals to provide drip protection and increased protection from short circuits. You need to install the boots before doing any other DC wiring. See “To install rubber boots:” on page 2–14.

To install DC wiring:

1. Identify the battery or bank that most frequently becomes deeply discharged. This bank will often be a deep cycle battery referred to as the House Bank on a boat, as opposed to an engine Start Battery. This high priority bank should be connected to bank 1 on the XC Series, which is the default bank.
2. Plan the route that the DC wires will follow, keeping it as short as possible. Measure and cut the required wire length. Allow some extra length for connections and to provide slack in the wires.
Note: The connection to the battery negative circuit may not be at a battery, but may be at an engine negative bus or a DC negative bus. If in doubt, consult the boat schematics.
3. Identify the positive wires, by using color-coded wire or by marking both ends of the wire with colored tape or similar kind of marking. Repeat with a different color for the negative. Most installation codes recommend coloring the positive red and the negative black.

Important: You may find it helpful to label each cable, associating it with the battery bank it is connected to. For example, bank 1 (-), bank 1 (+), bank 2 (-).

4. Install a DC circuit breaker or fuse/disconnect in each positive cable close to each battery. For your applications and jurisdiction, consult your local electrical codes regarding the distance between the battery and the disconnect device. Be sure the breaker is open or fuse is not inserted at this time.

5. Route the wiring to the batteries and to the XC Series, but don't connect it yet. Avoid routing wiring through an electrical distribution panel, battery isolator, or other device that will add voltage drops.
6. Install crimp lugs on each end of the battery cables using the crimp manufacturer's instructions and tool.
7. Install rubber boots over the charger end of the DC cables. Xantrex recommends that you install rubber boots over the XC Series DC terminals to provide drip protection. Follow the procedure on page 2–14 to install rubber boots.
8. Route the battery temperature sensor from each battery to the charger location.
9. Proceed to “Pre-Installing AC Wiring”.

Pre-Installing AC Wiring

Before connecting AC wiring, make sure the AC source circuit is protected by a breaker switch of the correct size and type, to comply with the electrical code for your location and application.

To install AC wiring:

1. Disconnect the AC source by turning off the breaker feeding the circuit, unplugging from shorepower and disconnecting any other power sources (such as a generator).
2. Plan the route that the AC wiring will follow from the source (usually an AC distribution panel) to the XC Series. Measure and cut the required length of three-conductor cable.
For example, in North America for 120 VAC use a 14 AWG wire with a 15 A breaker; or typically in Europe for 230 VAC use either a 2.5mm² wire with a 16 A, double pole breaker or fuse or use 1.5 mm² wire with a 10 A, double pole breaker or fuse. Note that every jurisdiction will have different requirements, so see the regulations for your local jurisdiction to determine which wire size and type is correct.
Allow some extra length for connections and to provide slack.
3. Make the AC connections to the back of the charger when it is sitting on a table or other convenient work surface.
Route the AC cables to the source after the charger is mounted in position.
4. Unscrew the wiring compartment cover from the left rear of the XC Series to expose the AC wiring access hole.

5. Install the cable strain relief on the XC Series end of the source AC cable.
6. Carefully remove 50 – 75 mm (2 – 3 in.) of the outer jacket, being careful not to cut or nick the insulation on the individual conductors.
7. Pull the XC Series pigtail wires out through the access hole.
8. Thread the source AC cable through the knockout beneath the wiring compartment cover and then pull it out through the access hole.

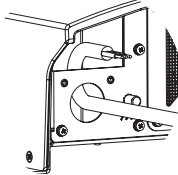

9. Connect the AC wiring to the XC Series pigtail wires, being sure to connect the line conductor to the line, the neutral to the neutral, and the ground to the ground. The pigtail wires are color coded as follows:

Conductor	Color code
Line	Black or brown
Neutral	White or blue
Ground	Green with yellow stripe

10. Make the connections with twist-on or crimp-on connectors or with other approved connectors suitable for your installation. For example, the ABYC Standards and Recommended Practices for Small Craft prohibit twist-on connectors for AC connections on a boat. For non-marine installations in locations not subject to vibration, either type of connector may be used. For marine installations, follow the procedure for installing butt splice connectors.

To connect AC wires with the crimp-on butt-splice connector:

Important: You must exercise care when crimping butt-splice connectors. Use the crimp tool recommended by the manufacturer for the connector used.

- a) Using a wire stripper, carefully strip 8 mm (5/16 in.) from the ends of the two wires being connected.
- b) Insert one wire into one end of the butt-splice, until the insulation hits the internal metal crimp section, insert the butt-splice into the crimping tool, and crimp firmly. The proper location for the crimp is approximately 1.6 mm (1/16 in.) past where the butt-splice insulation tapers down as shown.

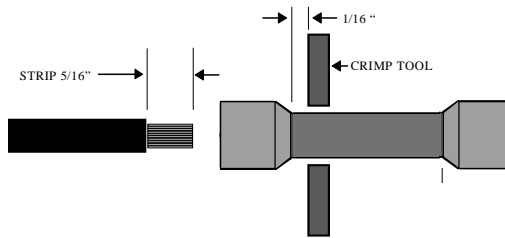

- c) Repeat Step b for the other end of the butt-splice.
- 11. Push the AC cable strain relief into the electrical junction box hole until it snaps into place.
 - 12. When all connections are completed, push the wiring and connectors inside the wiring compartment. Install the wiring compartment cover and fasten with the supplied blunt-tip screws and lockwashers.

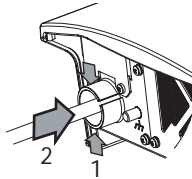

- 13. Proceed to “Mounting the Remote Display”.

Mounting the Remote Display



WARNING: Shock hazard

Even if you intend to leave the remote display in the shipped orientation in the XC Series, you must remove the remote display and secure it in place by removing the non-stick backing on the rear and pressing the remote display flanges in place. If you do not use the non-stick backing, the XC Series will not be drip protected.

To accommodate the charger mounting orientation, the remote display can be removed and turned 180 ° for readability. If you intend to mount the display remotely, up to 20 m (65 ft), remove the display before mounting the charger and secure the blank plate to cover the display socket on the unit.



CAUTION

Ensure you are placing the display in the correct orientation before removing the adhesive backing. The adhesive tape for attaching the remote is extremely strong and you may be unable to remove it without damaging the display or other equipment.

To remove the display:

1. Unplug the display cable from the telephone-type connector on the back of the unit.
2. Release the display cable from the retaining clips on the underside of the unit.
3. Remove the remote display from the charger and read and then remove the warning label that is attached to it.

To secure the display or blank plate on the unit:

1. Choose the display orientation that is appropriate for the charger orientation.
2. Remove the adhesive backing on the back of the display or blank plate .
3. Line up the display or blank plate with the display socket, making sure it is in the chosen orientation.
4. Firmly press the flanges in place. Do not press in the middle of the display.
5. Route the display's North American style telephone-type cable under the unit and plug the cable into the bottom connector on the rear panel of the unit.

To remotely mount the display:

1. Remove the display as described on page 2–7.
2. Secure the blank plate in the display socket as described.
3. Ensure that the extension cable used for the remote display is long enough to suit the installation. A standard North American style, 4 conductor (RJ-11) telephone cable extender is adequate.
4. Use the enclosed mounting template to cut a hole for the display in the chosen mounting surface.
Take care that there is nothing behind the surface for you to damage.
5. Feed the remote display extension cable through the hole and route it to the charger. Be careful not to damage the telephone connector locking tab when routing the cable. You can use some tape to protect the locking tab from catching on something and breaking off when routing the cable.
6. Remove the adhesive backing on the back of the display.
7. Line up the display with the mounting hole.
8. Firmly press the flanges in place. Do not press in the middle of the display.
9. Once the XC Series is mounted, plug the cable into the bottom connector on the rear panel of the XC Series.
10. Proceed to “Mounting”.

Mounting

Mount the XC Series using the mounting slots provided.

For marine installations, only the mounting configurations with a check mark in Figure 1-6 on page 1–11 meet the North American and European requirements. This is to ensure that any moisture that may be present will not enter the XC Series.

Important: Be sure to measure your AC and DC cables and plan the routing of the cables before drilling the pilot holes for mounting the XC Series.

To mount the XC Series:

1. Keep the carton and packing material in case you need to return the XC Series for servicing.
2. Ensure that you have selected a mounting surface that is clear, flat and allows for a minimum of 76 mm (3 in.) of clearance on each end for fan circulation.

3. Secure the enclosed mounting template to the mounting surface with tape.
4. Drill the six pilot holes for the mounting screws, taking care that there is nothing behind the surface that can be damaged by the drill.
5. Mount the XC Series using corrosion resistant, #6 (3 mm) round, pan head (or similar) screws.

The top two keyhole-style mounting holes can be used to hold the XC Series in place while fastening the bottom four screws. For secure, permanent mounting, use all six mounting slots.

Grounding



WARNING: Electric shock hazard

Do not make an ungrounded installation. Have an electrician install a properly grounded circuit if one is not available. Improper connection can result in risk of an electric shock.

The XC Series Battery Charger must be grounded to reduce the risk of electrical shock. The AC input ground wire of the charger must be properly connected to ground in accordance with the applicable electrical codes, this is usually a ground terminal in the AC distribution panel where the branch circuit originates.

Xantrex recommends that you install a DC chassis ground (earth) from the ground stud on the XC Series to the engine negative bus or DC ground bus. The DC chassis ground (earth) should not be more than one size smaller than the power conductors, and must be rated for the battery fuses that are used to protect the DC wiring. Refer to your local electrical codes to verify if this is required in your jurisdiction or in your application.

Proceed to “Final Connections”.

Final Connections

Once the DC cables, AC cables and XC Series are all in place the final connection may be made.

Figure 2-1 shows the connection order.

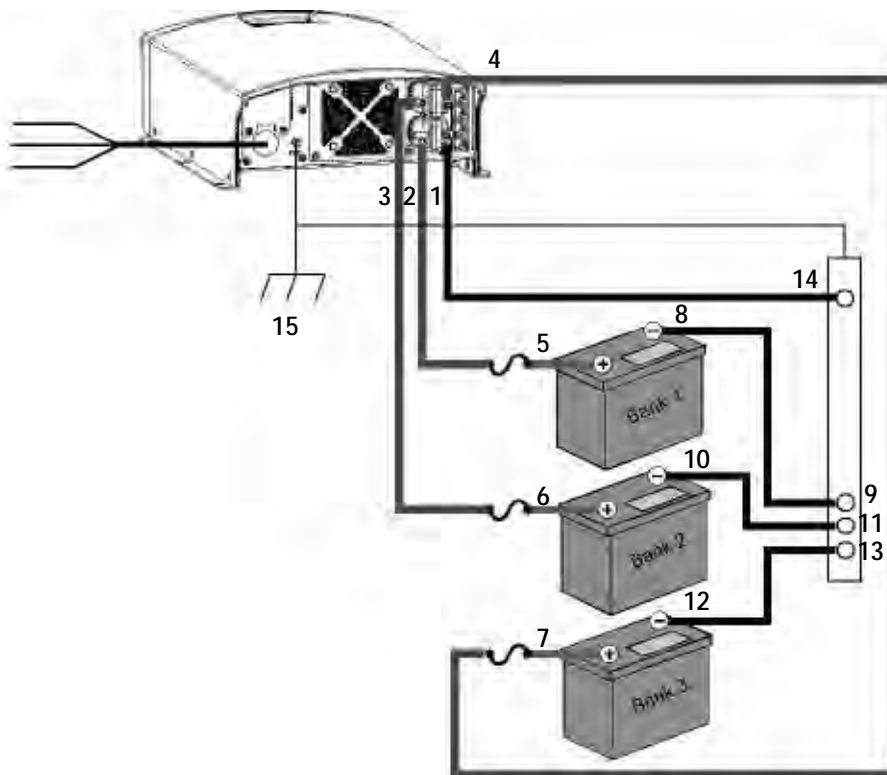

Figure 2-1 DC Wiring Connection Order

Final DC Connections



WARNING: Shock hazard

Make sure that the DC fuse or circuit breaker is still open.

To make the last DC connections:

1. Connect the negative cable from the negative terminal on the battery (if you are using only one battery or bank), or the negative ground bar or bus (if you are using more than one battery or bank), to the negative DC terminal on the XC Series (Figure 2-1). Use a flatwasher, a lockwasher and a nut (5 included in the installation kit) to secure the connection.
Tighten the nuts to 3 N-m (30 lb-in.) torque and test that the wire is secure.
2. Connect each positive cable to the correct positive DC terminal on the XC Series (Figure 2-1). Use a flatwasher, a lockwasher and a nut (5 included in the installation kit) to secure the connection.
Tighten the nuts to 3 N-m (30 lb-in.) torque and test that the wire is secure.
3. Connect the free end of each positive cable to the correct positive terminal of the battery, using sufficient torque as recommended by your battery manufacturer.
4. Connect the free end of the negative cable to the negative terminal on the battery, using sufficient torque as recommended by your battery manufacturer.
Note: If you are using more than one battery, you will need to connect the negative cable from each of the batteries to the negative ground bar or bus. The negative ground bar or bus will then have a single negative cable connecting to the negative charger terminal.
5. Before proceeding, carefully check the wiring polarity – make sure the positive terminals of the XC Series are connected to the correct terminals of the battery (fuses or breakers) and from there to the positive terminals of the battery. Make sure the negative terminal of the XC Series is connected to the battery negative terminal (or engine negative bus/DC negative bus). Do not reverse the connections.
6. Install the DC chassis ground (earth) from the ground stud on the XC Series to the engine negative bus or DC ground bus.
7. Connect the BTS cable and the remote display cable to the rear of the charger.

8. Secure cables in place using tie-wraps, P-clamps or cable straps according to electrical codes. Coil and tie any extra BTS or remote display extension cable.
9. The DC breakers may be closed or fuses inserted at this time.

Final AC Connections

To make the last AC connections:

1. Complete the installation by routing the AC cable to the AC source.
2. Connect the AC cable to the AC disconnect breaker and ground in accordance with the color codes on page 2–5.
3. Secure cables in place using tie-wraps, P-clamps or cable straps according to electrical codes.

Powering Up

Make one last check that all connections and connectors are secure.

The XC Series charger may now be powered up. Switch the AC power on at the source breaker. It is normal to see a 7-10 second delay while the unit powers up. During this time, the indicator lights on the onboard status panel and the remote display will not display any information.

At very low AC source voltages (for example, less than 105 VAC) the start up time will increase proportionally up to as much as 40 seconds.

Installing Optional Accessories

The XC Series ships with a battery temperature sensor (BTS) and drip protection rubber boots for the DC cables.

Battery Temperature Sensor

Xantrex strongly recommends that you install a Battery Temperature Sensor (BTS) to protect your battery and improve charging accuracy. It is best to use a separate BTS with each individual battery bank, to provide optimal charging and protection of each bank. If no BTS is connected, the charger defaults to the charging conditions for 40 °C (104 °F). At this temperature the charging voltage is lower to keep batteries from overcharging; charging will be slower and the batteries will be slightly undercharged.

One BTS is provided with with your XC Series and additional battery temperature sensors may be purchased separately.

To install a BTS:

1. Switch off all devices operating from the battery.
2. Connect the ring terminal on the sensor directly on to the negative battery stud, or affix the double-sided adhesive backing (included) to the sensor back and attach the sensor to the side of the battery to be monitored.
3. Route the sensor cable to the charger and plug it into the bank 1 (default if using only one BTS), bank 2 or bank 3 connector on the rear panel.

Drip Protection Rubber Boots

Xantrex recommends that you install the supplied rubber boots over the XC Series DC terminals to provide drip protection.

To install rubber boots:

1. Before making the DC connections to the charger, feed the rubber boot over the charger end of the DC cables.



2. Perform all other DC connections as described in “To install DC wiring:” on page 2–3.
3. After the DC cables are connected to the charger, slide the boot up the cables and over the DC terminals. If you are only using one battery, slide the spare boots over the unused DC terminals.

Configuring the XC Series

Once the charger is connected to a battery on bank 1 or to AC, it is live and it may be configured. There will be a short delay of about 15 seconds before the remote display begins reporting. The remote display will use this time to query the charger for the current operating conditions.

If AC was already applied, ensure that the charger is in on by pressing ON/STANDBY if necessary.

To configure the battery bank type:

1. Press and hold MODE until 5E5 (setup) is displayed.
2. Press TYPE to select the battery type configuration programming mode. The XC Series will default to Bank 1 and will show the present battery type setting.
3. Press BANK repeatedly to select which bank you are setting up. The bank indicator light will illuminate to show which bank has been selected.
4. Press TYPE repeatedly to select the battery type for each bank. When you have selected a battery type that is different from the present configuration, the bank indicator light flashes.

Set the TYPE according to the table below:

If your battery is	then select
Flooded Lead Acid (has removable caps intended for refilling)	FLA
GEL (any sealed type except AGM)	GEL
Absorbed Glass Mat (AGM)	AGM
Lead Calcium	LdC
Custom (if pre-configured at factory)	CU5

5. Press and hold ON/STANDBY until 5E5 is displayed to store the selected battery type. If no is displayed, verify that you are setting the correct battery type and try again.
6. Repeat steps 1 through 4 for all banks attached to the XC Series. Each time 5E5 is displayed for a newly programmed battery type, the charger exits the programming mode.
7. At any time during setup, you can press ON/STANDBY once to cancel the current change and return to charging or battery monitoring.

To configure the charging type:

1. Press and hold MODE until 5E£ (setup) is displayed.
2. Press MODE to select 2-stage (25£) or 3-stage (35£) charging. When you have selected a charging type that is different from the present configuration, the bank indicator light flashes.
See “About Charging” on page 3–2.
3. Press and hold ON/STANDBY until 4E5 is displayed to store the selected mode.
4. At any time during setup, you can press ON/STANDBY once to cancel the current change and return to charging or battery monitoring.

3

Operation

Chapter 3 describes the operating states and provides procedures for charging a battery and performing an equalization.

About Charging

The XC Series has three full current rated, independently controlled outputs which enable it to charge three different batteries or battery banks. Each output can accommodate any one of the four allowable battery types, regardless of what battery types are connected to the other outputs. Each output can be in a different stage of charge, relative to the other banks; for example, Bank 1 in float, Bank 2 in absorption and Bank 3 in bulk. Each bank can accommodate a separate battery temperature sensor. The XC Series can also perform either multiplex (3 stage) charging, or sequential (2 stage) charging.

Important: The battery banks are not galvanically isolated from each other. They share a common negative.

Multiplex 3-Stage Charging

In multiplex charging mode the charger will check all qualified battery banks every 15 seconds to determine which bank is most in need of charging. That bank will then be charged for the next 15 seconds. Every 15 minutes the charger will query all outputs and detect which battery banks are present and healthy.

The multiplex charging mode employs the 3-stage charging algorithm: Bulk, Absorption, and Float. During the Bulk stage the battery is accepting high current. In the Absorption stage the battery voltage is held constant and the current declines. A battery will also "gas" (produce hydrogen and oxygen) during this stage. Finally, in the Float stage, the charger continues to provide voltage at a lower level to maintain the battery in a fully charged state. If there is no load on the battery, it will typically draw very little current. The charger, however, is able to provide current to its full rating to power DC loads on the battery. In float, if batteries are very new or a battery is on the low end of the size range and if it is fully charged to the point where it will not accept any more current, then the charger will enter an adaptive float/no float behaviour where it will alternate between float charging ($F_{L\alpha}$) and resting the battery (r_{dY}).

The charger will restart the charging cycle in the Bulk stage if the battery voltage drops below 12.5 V (12 V units) or 25 V (24 V units) for 15 minutes. After 21 days, the charger will automatically restart charging in order to refresh the batteries.

Sequential 2-Stage Charging

In sequential charging mode the charger will check all battery banks every 15 minutes to determine which banks are present, healthy, and in most in need of charge. The bank most in need of charge will then be charged for the next 15 minutes.

The sequential charging mode employs the 2-stage charging algorithm. It is the same as the 3-stage algorithm except that there is no float stage; after the absorption stage the charger stops providing voltage and current to the battery and enters a "rest stage". Like the 3-stage algorithm, the charger will restart the charging cycle in the Bulk stage if the battery voltage drops below 12.5V (12 V units) or 25 V (24 V units) for 15 minutes. After 21 days, the charger will automatically restart charging in order to refresh the batteries.

Charging Overview

The XC Series will perform a battery detection sequence every 15 minutes, or on reapplication of AC, to determine which battery banks are present and healthy.

If you connect a battery when AC is disconnected, the remote will not recognize it until the unit has performed a battery detection with AC applied.

To force a battery detection sequence,

1. Turn off AC.
2. Wait approximately 20 seconds or until all lights on the charger or remote have gone out .
3. Turn on AC.

The charger will then perform a battery detection when AC is reapplied

The charger does not charge the banks in a pre-determined sequence. The bank most in need of charging is the one that receives the charge. For example, if Bank 1 and Bank 2 are both charged, but Bank 1 has a load and Bank 2 does not, then the charger may rarely charge Bank 2.

Disqualified Batteries

The XC Series can identify when a battery will not accept a charge (battery is damaged) or when it is fully charged (healthy) and does not require further charge. Batteries that will not accept a charge will be removed (disqualified) from the charging sequence until all banks are checked again (every 15 minutes). A damaged battery will continue to be disqualified each cycle and the charger will not waste energy trying to charge it. Under some conditions it is also possible that a healthy battery that is fully charged but unable to accept current (for example, at the moment it transitions from Absorption to Float or Rest) will be deemed unable to be charged and temporarily removed from the charging sequence. The charger will enter an adaptive float/no float behaviour where it will alternate between float charging (FLD) and resting the battery (RDY) and the 25% Charge Current indicator light on the onboard status panel will flash. The battery will be evaluated every 15 minutes and added back to the charging sequence when it is later able to accept charge.

If disqualification occurs during Bulk or Absorption, the battery is damaged or there is another charging source present other than the charger itself. The remote display will show d15 and the 25% Charge Current indicator light on the onboard status panel will flash.

Measuring Battery Voltage

Use a voltmeter that has a stated accuracy of 0.5% or better on DC voltage. Place the probes of the meter directly on the studs or plates of the charger terminals. Do not probe on the wire lugs or other places in the battery wiring system as this will introduce error into the measurement: the charger monitors battery voltage as measured at the charger terminals.

Temperature Considerations

Xantrex strongly recommends that you install a Battery Temperature Sensor (BTS) to protect your battery and improve charging accuracy. It is best to use a separate BTS with each individual battery bank, to provide optimal charging and protection of each bank. If no BTS is connected, the charger defaults to the charging conditions for 40 °C (104 °F). At this temperature the charging voltage is lower to keep batteries from overcharging; charging will be slower and the batteries will be slightly undercharged.

Things to be aware of

When the XC Series is operating, fans and lights (DC loads) may vary in speed or intensity. This is normal. The XC Series will not harm any load connected to it as long as there is a battery present on that bank.

When you initially turn the XC Series on and configure it, it is possible that some banks may be disqualified. Because the charger is able to detect unhealthy batteries and disqualify them, batteries that may have appeared healthy before will now be correctly identified as needing attention.

Perform these disqualification checks in the order shown:

1. Wait 15 minutes for the next battery detection cycle. The warning may be temporary.
2. Verify that the battery meets the minimum AmpHour rating (XC1524: 30 Ah, XC2524: 50 Ah, XC3012: 60 Ah, XC5012: 100 Ah)
3. Try adding a small DC load.
4. Replace the battery.

Charging Batteries

Before you start to charge batteries read the “Important Safety Instructions” on page v and follow all safety precautions when working with batteries.

To charge your batteries:

1. If possible, disconnect all loads from the battery, by opening a disconnect switch, or by switching the loads off.
2. Ventilate the area around the battery thoroughly. Review the charging instructions supplied by the manufacturer of your batteries and take any steps required.
3. Apply AC power to the XC Series by closing the AC breaker and/or applying shorepower or turning the generator on. The indicator lights will blink as an initialization sequence runs, lasting typically 10 seconds. After initialization the charging indicator light illuminates.
 During charging, the charging current indicator lights show the total current being delivered to the selected battery bank as well as any DC load applied.
4. Re-connect all loads to the battery, by closing a disconnect switch, or by switching the loads on.

The batteries can be in one of six different stages:

Mode	Remote Display
Bulk mode	<i>bUL</i>
Absorption mode	<i>Ab5</i>
Rest mode (2-stage charging)	<i>r dY</i>
Float mode (3-stage charging)	<i>FL0</i>
Equalize mode	<i>EQU</i>
Battery fault	<i>Err</i>

After charging is complete, the XC Series enters into one of these modes:

Float mode When the ready indicator light illuminates, all batteries are fully charged and ready for use. If you selected the 3-stage charging mode, the XC Series is in float mode and will maintain the batteries' charge.

Rest mode If you selected the 2-stage charging mode, the ready indicator light shows the charger is now in rest mode and is checking battery voltage and elapsed time since the last charge cycle.

With either charging mode, the XC Series will begin a charging cycle 21 days after the last cycle, or when battery voltage drops to below 12.5 V (12 V units) or 25 V (24 V units) for 15 minutes.

Equalizing Flooded Batteries

About Equalizing

The XC Series equalizes only flooded lead-acid or lead-calcium batteries. It does not equalize sealed lead-acid batteries since they can be damaged by this process.

In the following conditions the remote display will show $n0$ and the XC Series will not enter equalization mode:

- the battery type is set for Gel or AGM
- any battery is not fully charged (all three battery banks must be charged to float or rest stage before equalization can be activated on any bank)
- there is an active fault on the battery you are trying to charge

Xantrex recommends that you run a normal charge cycle on the batteries before you equalize them.



WARNING: Explosion hazard

During equalization, the battery generates explosive gases. Follow all the battery safety precautions listed in this guide. Ventilate the area around the battery thoroughly and ensure that there are no sources of flame or sparks in the vicinity



CAUTION: Risk of battery damage

The XC Series cannot automatically determine when to stop the equalization of a battery. You must monitor the battery specific gravity throughout equalization to determine the end of the equalize cycle. The one hour time-out is intended as a safety feature to require the user to continually re-activate it as necessary after checking batteries manually, but may not be sufficiently short to prevent battery damage.

Performing An Equalization

Turn off or disconnect all DC loads on the battery during equalization. The voltage applied to the battery during equalization may be above the safe levels for some loads.

To equalize your batteries:

1. Check the battery electrolyte level. If necessary, refill with distilled water only. All the cells should have similar electrolyte levels. If the levels are widely different, it will influence the relative concentration of acid, thereby affecting the specific gravity measurements.
2. Verify that all banks are in either float or rest mode.
3. Press MODE and BANK at the same time.
4. Press BANK to select which bank you wish to equalize. The bank indicator light will flash to show which bank has been selected.
5. Press and hold ON/STANDBY to put the XC Series into equalization mode. You can cancel the equalization request by pressing ON/STANDBY once. If the battery cannot be equalized, the display will show \square . Check that the battery is flooded and in float mode.
6. When the charger is in equalize mode, the display will show E^9U .
7. Monitor the specific gravity of each cell of the battery during equalization with a battery hydrometer.
The equalize cycle will terminate in one hour.
Check the specific gravity of each cell and repeat the equalization cycle until they all meet the battery manufacturer's specifications for specific gravity or until the specific gravity stabilizes relative to each other for an hour.
8. The charger automatically exits equalization to float mode or rest mode after 1 hour. To manually exit equalization mode early, press MODE and BANK at the same time and then press and hold ON/STANDBY.
You can cancel the manual exit request by pressing ON/STANDBY once.
9. When equalization has finished, check the battery electrolyte level. If necessary, refill with distilled water only.

Transitioning the XC Series to On, Disabled or Off

There are two ways to turn the XC Series on:

- connect AC power at the source
- press ON/STANDBY on the remote display if AC is still connected.

There are two ways to disable the XC Series:



WARNING: Shock hazard

The XC Series still has live voltage while disabled. Even when AC power is removed, if the XC Series is connected to a battery on bank 1, the unit will take power from the battery. The only time the XC Series is de-energized completely is when both AC and DC are disconnected.

- disconnect AC power at the source
- press ON/STANDBY on the remote display.

The XC Series continues to monitor the batteries, but will not charge them.

There is only one way to safely turn the XC Series off:

- disconnect the AC power at the source and disconnect all DC batteries.

This is the only state where the XC Series is completely discharged.

When the XC Series is disabled or off, the remote display is inactive.

Accessing Charger Information

The XC Series can give you a lot of information about the status of the charger and the batteries.

Reading Remote Display and Onboard Status Indicator Lights

The remote display and onboard status panel show what is happening during the charging process and are also helpful in troubleshooting. Refer to Chapter 4, “Troubleshooting” for more information about interpreting the remote display and onboard status indicator lights.

The remote display is designed to report on the active status of the charger. While the unit is charging, the remote display reports only on the battery being charged at that moment. It does not report the status of other batteries.

The Ready light on the onboard status indicator panel only illuminates when all connected banks have reached float (F_{LD}) of 3-stage charging or rest (r_{dY}) of 2-stage charging. If one of the three batteries has been disqualified before it reaches float/rest stage, while the others have reached float (F_{LD}) of 3-stage charging or rest (r_{dY}) of 2-stage charging, the Ready light on the onboard status indicator panel will not illuminate.

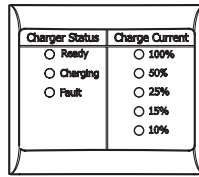

Table 3-1 Reading XC Series Status

Charger Status	Remote Display	Onboard Status Indicator Lights
<p>Charging in bulk or absorption mode. Remote display shows scrolling display of charging state, battery voltage in volts and charging current in amps. Indicator lights indicate the charging current in % of full charge. At transition points when the current is changing, two indicator lights may flash alternately, then settle into the new charging current reading.</p>	<i>bUL</i> or <i>Ab5</i>	Charging indicator light illuminates
<p>Equalizing. Charging indicator light flashes once every four seconds if bank 1 is being equalized, twice every four seconds if bank 2 is being equalized, and three times every four seconds if bank 3 is being equalized.</p>	<i>EQ</i>	Charging indicator light flashes
<p>Float mode of three stage charging or rest mode of two stage charging. All batteries have been fully charged.</p>	<i>FL0</i> or <i>rd4</i>	Ready indicator light illuminates
<p>A battery has been disqualified while in float mode of three stage charging or rest mode of two stage charging.</p>	<i>FL0</i> or <i>rd4</i>	25% current indicator light flashes
<p>A battery has been disqualified while in bulk or absorption mode.</p>	<i>d 5</i>	25% current indicator light flashes
<p>Non-charger fault condition. Any fault condition that prevents the charger from charging one or more banks, but is not a charger failure. Remote display shows details of fault.</p>	<i>Err</i> <i>bAt</i> <i>PoL</i> (example)	Fault indicator light illuminates

Table 3-1 Reading XC Series Status

Charger Status	Remote Display	Onboard Status Indicator Lights
Battery too hot fault	<i>Err</i> <i>Hot</i>	Fault indicator light illuminated 100% current indicator light flashes
Battery too cold fault	<i>Err</i> <i>Cld</i>	Fault indicator light illuminated 10% current indicator light flashes
Charger fault condition. The charger is damaged, contact service.	<i>Err</i> <i>CHF</i>	Fault indicator light flashes

Reporting While Charging or Equalizing

After configuration, the XC Series defaults to a scrolling display. As long as there are no faults or errors to report, the remote will display the following information, in order, for the bank presently being charged:

- Charging Stage
- Battery Voltage
- Charger Current

If there is a fault or warning related to one of the banks, the fault or warning information will display in the scrolling display before the charging state for the bank presently being charged. Charging for banks not in fault will continue (see “Error Messages on Remote Display” on page 4–4). Charging for the bank in fault will resume once the fault condition is cleared.

Reporting While Battery Monitoring

The XC Series is considered to be battery monitoring if it is experiencing a charger level fault. If there is a charger level fault (affecting all banks), all charging will be suspended until the charger fault is resolved (see “Error Messages on Remote Display” on page 4–4).

The remote will display all of the following, in order:

- Highest level charger fault or warning (if present)
- Bank 1 Highest level bank fault or warning (if present)
- Bank 1 Charging Stage
- Bank 1 Battery Voltage
- Bank 1 Charger Current
- Bank 2 Highest level bank fault or warning (if present)
- Bank 2 Charging Stage
- Bank 2 Battery Voltage
- Bank 2 Charger Current
- Bank 3 Highest level bank fault or warning (if present)
- Bank 3 Charging Stage
- Bank 3 Battery Voltage
- Bank 3 Charger Current

Reporting While Disabled

If AC power has been disconnected or if you have used the remote display to disable the XC Series the unit is considered to be disabled. The remote display is also disabled at this time.

While the XC Series is disabled, you may wish to see the present status of the banks.

To view the present status of the banks:

- ◆ Press ON/STANDBY.

If AC power is disconnected, the remote display will show one cycle (similar to the battery monitor cycle) for each bank that was qualified as present and healthy during the last battery detection cycle. The remote display will turn itself off after one complete cycle.

- ◆ Press ON/STANDBY on the optional remote display to initialize another cycle.

If AC power is connected, the XC Series will turn on, check which battery banks are present and healthy, and begin charging.

While the XC Series is off, and a fault is present, the remote display will turn itself on approximately once per minute to show the fault and then turn itself off.

Using A Generator As Source Power

The XC Series can be run from a regular power source or from an alternate power source such as a generator. Refer to Appendix A, “Specifications” for AC input draw to determine the size of generator you need. Many generators provide output voltage that is modified sine wave or modified square wave (MSW) rather than the true sine wave (TSW) that your utility provides.

The XC Series may be used with MSW generators but the lifetime may be reduced somewhat depending on the severity of any peak voltage overshoots, and the severity of waveshape risetimes.

4

Troubleshooting

Chapter 4 contains information on error codes and procedures for troubleshooting your XC Series charger.

Care and Maintenance



WARNING: Risk of electric shock

The XC Series contains no user serviceable components. Attempting any kind of service will void your warranty. Contact your dealer or the manufacturer for service information.

The XC Series contains solid-state electronic components that require no maintenance. The best care you can give the unit is to protect it from contact with liquids, spray, or fumes which may cause corrosion. Disconnect all AC and DC power and clean the outside of the case and wiring with a damp cloth if you suspect it has come in contact with battery fluid, salt water, gasoline or oil, or other corrosive material. Periodically, check all DC and AC wiring connections to be sure they have not loosened or deteriorated. Also check all cable clamps to ensure they are tightly fastened.

Loose battery terminals and lugs exposed to open air corrode rapidly. The corrosion appears as a white powder or granular foam on the terminals and any nearby exposed metal parts. If it contacts your skin, it will cause burns unless you rinse it off immediately. Most textiles that are exposed to this corrosive eventually dissolve.

To clean battery terminals:

1. Disconnect all loads and charging sources.
 2. Using the appropriate tool, remove the negative battery cable first and re-install it last.
 3. To remove any stubborn residue, sprinkle baking soda directly on the area, scrub with a wet toothbrush (or other soft-bristle brush), add water as required, and then rinse.
-



CAUTION

Take care not to allow any washing solution to enter the battery filling caps in the case of a flooded battery, as any contamination into a cell will chemically damage it.

4. Reconnect the battery cable terminals to the battery lugs and tighten.
 5. After tightening the cables, evenly coat all the exposed metal surfaces of the battery terminals and lugs with liquid neoprene. If liquid neoprene is not available, use a light coating of anti-corrosion grease or other sealant. Do not let anything come between the mating surfaces of the lugs and terminals.
-

Indicator Light Flashing Sequences

Table 4-1 Indicator Light Sequences on the XC Series

Activity	Charger status
Charging indicator light illuminates	The unit is charging in bulk or absorption mode
Charging indicator light flashes	The unit is performing the equalization charge. (Charging indicator light flashes once every four seconds if bank 1 is being equalized, twice every four seconds if bank 2 is being equalized, and three times every four seconds if bank 3 is being equalized)
Ready indicator light illuminates	The unit is either in float mode of three stage charging or rest mode of two stage charging. All batteries have been fully charged.
Fault indicator light illuminates	Any fault condition that prevents the charger from charging one or more banks, but is not a charger fault condition - remote display shows details of fault. Example: <i>Err bAt Pol</i> (battery reverse polarity detected)
Fault indicator light flashes	Charger fault condition - remote display shows <i>Err</i> followed by <i>CHF</i> . The charger is damaged, contact service.
Charging current indicator lights illuminate	These lights indicate the charging current. At transition points when the current is changing, two indicator lights may flash alternately, then settle into the new charging current reading.
Charging current indicator lights flash	100% indicator light flashes to indicate battery temperature too high warning (> 50 °C, 122 °F) 10% indicator light flashes to indicate battery temperature too low warning (< 0 °C, 32 °F) 25% indicator light flashes to indicate that a battery has been disqualified (see page 3–4)
Charging current indicator lights flash, Fault indicator light illuminated	100% indicator light flashes to indicate battery temperature too high fault (> 55 °C, 131 °F) 10% indicator light flashes to indicate battery temperature too low fault (< -20 °C, -4 °F)

Error Messages on Remote Display

Table 4-2 Error Messages

Display	Onboard Status Panel Indicator lights	Fault	Solution
<i>Err</i>	Red fault indicator light flashing or illuminated	Fault	A fault has been detected. The fault code will be shown immediately after <i>Err</i> .
<i>ACL</i>		AC Low Warning	Check AC connections, check AC availability at source.
<i>Err</i> <i>bAt</i> <i>Pol</i>	Red fault indicator light illuminated	Reverse Polarity	Reverse Polarity Battery connected. Check connections. Ensure correct polarity (negative connected to negative, positive connected to positive).
<i>Err</i> <i>[HF</i>	Red fault indicator light flashing	Charger Hardware Fault	Call for service.
<i>[HG</i> <i>Hot</i>		Over-temperature Warning	Allow the XC Series to cool. Improve ventilation or install in cooler location. If the temperature increases, the XC Series will enter the fault level and stop functioning.
<i>Err</i> <i>[HG</i> <i>Hot</i>	Red fault indicator light illuminated	Over-temperature Shutdown	Allow the XC Series to cool. Improve ventilation or install in cooler location.
<i>[Ld</i>	Green 10% indicator light flashes Display green bank indicator light for affected battery bank illuminated	Battery Too Cold Warning	Allow batteries to warm up before attempting to charge again. Charging a battery that has frozen is a potential explosion hazard. If the temperature drops, the XC Series will enter the fault level and stop charging the affected bank.

Table 4-2 Error Messages

Display	Onboard Status Panel Indicator lights	Fault	Solution
<i>Err</i> <i>LLd</i>	Red fault indicator light illuminated Green 10% indicator light flashes Display green bank indicator light for affected battery bank illuminated	Battery Too Cold Shutdown	Allow batteries to warm up before attempting to charge again. Charging a battery that has frozen is a potential explosion hazard.
<i>dl</i> 5	25% current indicator light flashes	Battery Disqualified Warning	Wait 15 minutes for the next battery detection cycle. The warning may be temporary. Verify that the battery meets the minimum AmpHour rating (XC1524: 30 Ah, XC2524: 50 Ah, XC3012: 60 Ah, XC5012: 100 Ah) Try adding a small DC load. Replace the battery.
<i>Hl</i>	Display green bank indicator light for the affected battery bank illuminated	Over Voltage Shutdown Warning	Check battery. Do not charge a battery rated at more than 12 volts nominal (XC3012, XC5012) or 24 volts nominal (XC1524, XC2524). Disconnect or turn off other charging sources such as the alternator or the charger on a generator with electric start. If the warning level escalates without being corrected, the XC Series enter the fault level and stop charging the affected bank.
<i>Err</i> <i>Hl</i>	Red fault indicator light illuminated Display green bank indicator light for the affected battery bank illuminated	Over Voltage Shutdown	Check battery. Do not charge a battery rated at more than 12 volts nominal (XC3012, XC5012) or 24 volts nominal (XC1524, XC2524). Disconnect or turn off other charging sources such as the alternator or the charger on a generator with electric start.

Table 4-2 Error Messages

Display	Onboard Status Panel Indicator lights	Fault	Solution
<i>Hot</i>	Green 100% indicator light flashes Display green bank indicator light for the affected battery bank illuminated	Battery too Hot Warning	Allow battery to cool. Improve ventilation or install in cooler location. It may indicate a shorted cell in the battery or excessive water loss. If the temperature increases, the XC Series will enter the fault level and stop charging the affected bank.
<i>Err Hot</i>	Red fault indicator light illuminated Green 100% indicator light flashes Display green bank indicator light for affected battery bank illuminated	Battery too Hot Shutdown	Allow battery to cool. Improve ventilation or install in cooler location. It may indicate a shorted cell in the battery or excessive water loss.
<i>no</i>		Cannot apply change	The operation you have tried to execute cannot be completed.
<i>Err no bat</i>	Red fault indicator light illuminated	No batteries detected	The charger did not detect any batteries.

Problem Solving

If the remote display is not functioning, troubleshoot your XC Series using the tables below. In the event that you have a problem with your XC Series, the following tables will help you to identify the problem and offer possible solutions to the problem.

Symptom

Indicator lights do not illuminate when charger is connected to AC power.

Possible Cause	Solution
No power at AC source and no battery connected on bank 1	Ensure that power is available at the source and a battery or bank is connected on bank 1
Defective AC wiring	Replace wiring
Charger level fault	Call for service

Symptom

Fault indicator light illuminates. XC Series stops functioning.

Possible Cause	Solution
XC Series does not detect battery for one of following reasons: <ul style="list-style-type: none"> • poor connection • reverse polarity connection • damaged wiring 	Check quality of battery connection and wires. Ensure correct polarity (negative connected to negative, positive connected to positive).
XC Series internal temperature too hot	Allow the XC Series to cool. Improve ventilation or install in cooler location.

Symptom

Fault indicator light flashes. XC Series stops functioning.

Possible Cause	Solution
XC Series hardware failure	Call for service

Symptom

Fault indicator light illuminates. 100% indicator light flashes.

Possible Cause	Solution
Battery temperature is too hot for safe charging.	Allow battery to cool. Improve ventilation or install in cooler location. It may indicate a shorted cell in the battery or excessive water loss.

Symptom

Fault indicator light illuminates. 10% indicator light flashes.

Possible Cause	Solution
Battery temperature is too cold for safe charging.	Allow batteries to warm up before attempting to charge again. Charging a battery that has frozen is a potential explosion hazard.

Symptom

XC Series completes a charging cycle, but the battery voltage seems (about 2 volts) too low.

Possible Cause	Solution
Battery has a shorted cell.	Check the battery. Verify you are attempting to charge a battery correctly rated at 12 volts nominal (XC3012, XC5012) or 24 volts nominal (XC1524, XC2524). Re-check the battery voltage with all loads removed and the battery is at rest for about an hour.

Symptom

The XC Series appears to be taking too long to charge battery. Ready indicator light does not illuminate after 24 hours of charging.

Possible Cause	Solution
Battery capacity is too high for the XC Series model.	Use a higher capacity charger.
Load connected to battery is draining charge current so that battery does not recharge.	Disconnect load or switch load off.
Battery has a damaged cell.	Replace battery.

Symptom

The XC Series will not transition to equalization mode.

Possible Cause	Solution
Battery is the wrong type, or set to the wrong type to equalize.	Verify battery type is set to Gel or AGM. These battery types cannot be equalized.
Not all batteries are fully charged.	Wait for all batteries to be in float (FLD) of 3-stage charging or rest (RDH) of 2-stage charging before attempting to equalize (the ready indicator light will illuminate).
An active fault is present on the bank you are attempting to equalize.	Clear the active fault (see Table 4-2 on page 4-4)

A

Specifications

Appendix A details the specifications for the XC Series.

Physical Specifications

Dimensions	Base unit: 367 mm x 240 mm x 106 mm 14.45 in. x 9.45 in. x 4.17 in. Remote Display: 118 mm x 41 mm x 32 mm 4.65 in. x 1.6 in. x 1.26 in.
Weight	5.7 kg (12.6 lbs)
AC input connections	Two color-coded No. 16 AWG wires (L, N) and one No. 18 AWG (G) minimum 152 mm (6 in.) long in a separate AC wiring enclosure with 21.3 mm (0.84 in.) hole provision for connection of a ½ inch North American "trade size" cable clamp or conduit hub or international PG 13.5 or PG16 or M20 gland or cable strain relief fitting.
DC output connections	Four right-angle M6 studs (3 positives and 1 common negative) for battery cable ring terminals and one M6 mm DC equipment ground

Electrical Specifications

Number of battery bank outputs	3 isolated, independently controlled outputs			
Nominal battery voltage	12 V units: 12 VDC 24 V units: 24 VDC			
Normal operating output range	12 V units: 0 – 16 VDC 24 V units: 0 – 32 VDC			
Nominal operating AC voltage	110 – 240 VAC			
Rated DC output current (total)	XC3012: 30 A (up to 15 V) XC5012: 50 A (up to 15 V) XC1524: 15 A (up to 30 V) XC2524: 25 A (up to 30 V)			
Absorption voltage (in VDC for XC3012 and XC5012) (Multiply VDC by 2 to get the absorption voltage for XC1524 and XC2524)		50 °C (122 °F)	25 °C (77 °F)	<0 °C (32 °F)
	Flooded	13.7	14.4	15.1
	Gel	13.5	14.2	14.9
	AGM	13.8	14.3	14.8
	Lead-calcium	14.8	15.5	16.0

Float voltage (in VDC for XC3012 and XC5012) (Multiply VDC by 2 to get the float voltage for XC1524 and XC2524)		50 °C (122 °F)	25 °C (77 °F)	<0 °C (32 °F)
	Flooded	12.8	13.5	14.2
	Gel	13.1	13.8	14.5
	AGM	12.9	13.4	13.9
	Lead-calcium	12.8	13.5	14.2
Equalize mode current	50% rated output			
Equalize mode—maximum output voltage	XC3012:	16.0 VDC		
	XC5012:	16.0 VDC		
	XC1524:	32.0 VDC		
	XC2524:	32.0 VDC		
Off-state current draw (with remote installed)	XC3012:	<20 mA		
	XC5012:	<20 mA		
	XC1524:	<15 mA		
	XC2524:	<15 mA		

AC Input Specifications

AC input voltage range	100 – 260 VAC at full power 90 – 105 VAC at 80% restricted load Note: Charger may not start with input voltage <100 VAC	
Maximum AC input current	at 100 VAC	at 184 VAC
	XC3012: 6 AAC	XC3012: 4.3 AAC
	XC5012: 10 AAC	XC5012: 5.7 AAC
	XC1524: 6 AAC	XC1524: 4.3 AAC
	XC2524: 10 AAC	XC2524: 5.7 AAC
Power factor at rated load	≥0.95	
Frequency	47 – 63 Hz	
Efficiency – peak	12 V units: 80% @ 120 VAC, 83% @ 230 VAC 24 V units: 85% @ 120 VAC, 87% @ 230 VAC	
Surge protection	Line-to-neutral surge protector rated at 275 VAC	

Temperature Specifications

Nominal ambient	25 °C (77 °F)
Operating range	0 – 50 °C (32 – 122 °F)
Current de-rating	approx. 2% (I _{max}) / °C (50 – 65 °C) (122 – 149 °F)
Storage	-40 – 80 °C (-40 – 176 °F)
Humidity	5 – 95%, RH non-condensing

Protection Features

Battery reverse polarity	No damage incurred by reverse polarity.
Safe non-operating battery voltage	35 VDC maximum
Over-voltage limits	The XC Series will stop charging any bank that has a voltage greater than + 0.5 V over the temperature compensated absorption voltage. It will restart when this voltage is + 0.2 V.
Output current limit	XC3012: 30 – 33 ADC XC5012: 50 – 55 ADC XC1524: 15 – 16.5 ADC XC2524: 25 – 27.5 ADC
Over-temperature	Internal charger temperature is measured. Unit shuts down and restarts as follows: <ul style="list-style-type: none"> • Over-temperature shutdown at 75 °C (167 °F) • Over-temperature restart at 70 °C (158 °F)
Current derating in ambient temperatures	Rated current to 50 °C (122 °F) 2%/ °C derating above 50 °C (122 °F)
Battery over-temperature protection	Battery temperature, as sensed by the battery temperature sensor (if installed), results in the charger no longer charging the individual battery or bank at a battery temperature of 55 °C (132 °F).

Approvals

Safety	CSA/NRTL approved to CSA107.2 and UL1236, including the marine supplement, ignition protection, and UL1564 EN60335-1, EN60335-2-29 Battery Chargers ISO 8846: Ignition Protection for Small Craft ABYC E11 - Alternating Current and Direct Current Electrical Systems on Boats ABYC A20 - Battery Charging Devices NFPA70/1996 US NEC for home and RV installation requirements
EMC	FCC Class B CE marked, meeting EMC Directive 89/336/EEC (referencing EN55014-1, EN55014-2, EN61000-3-2, EN61000-3-3, EN61000-4-2, EN61000-4-3, EN61000-4-4, EN61000-4-5, EN61000-4-6, EN61000-4-11) CISPR25 (similar to SAE J1113-41) Class 1 on DC outputs
Other	KKK-A-1822 Rev D - Federal Specification for the Star-of-Life Ambulance

Warranty and Product Information

Limited Warranty for:

Xantrex XC3012 Battery Charger
Xantrex XC5012 Battery Charger
Xantrex XC1524 Battery Charger
Xantrex XC2524 Battery Charger

"XC Series"

What does this warranty cover and how long does it last? This Limited Warranty is provided by Xantrex Technology Inc. ("Xantrex") and covers defects in workmanship and materials in your Xantrex XC Series product. This warranty lasts for a Warranty Period of 24 months from the date of purchase at point of sale to you, the original end user customer. This Limited Warranty is transferable to subsequent owners but only for the unexpired portion of the Warranty Period.

What will Xantrex do? Xantrex will, at its option, repair or replace the defective product free of charge, provided that you notify Xantrex of the product defect within the Warranty Period, and provided that Xantrex through inspection establishes the existence of such a defect and that it is covered by this Limited Warranty. Xantrex will, at its option, use new and/or reconditioned parts in performing warranty repair and building replacement products. Xantrex reserves the right to use parts or products of original or improved design in the repair or replacement. If Xantrex repairs or replaces a product, its warranty continues for the remaining portion of the original Warranty Period or 90 days from the date of the return shipment to the customer, whichever is greater. All replaced products and all parts removed from repaired products become the property of Xantrex.

For United States and Canada returns, Xantrex covers both parts and labor necessary to repair the product, and return shipment to the customer via a Xantrex-selected non-expedited surface freight within the contiguous United States and Canada. Alaska and Hawaii are excluded. Contact Xantrex Customer Service for details on our freight policy for return shipments outside of the contiguous United States and Canada.

How do you get service? If your product requires troubleshooting or warranty service, contact your dealer. If you are unable to contact your dealer, or the dealer is unable to provide service, contact Xantrex directly at:

Phone: 1 800 670 0707 (toll free North America)
+34 93 470 5330 (Europe)
1 360 925 5097 (direct and rest of world)

Fax: 1-800 994 7828 (toll free North America)
+34 93 473 6093 (Europe)
1 360 925 5143 (direct and rest of world)

Email: customerservice@xantrex.com (North America and rest of world)
support.europe@xantrex.com (Europe)

Direct returns may be performed according to the Xantrex Return Material Authorization Policy described in your product manual. For some products, Xantrex maintains a network of regional Authorized Service Centers. Call Xantrex or check our website to see if your product can be repaired at one of these facilities.

In any warranty claim, dated proof of purchase must accompany the product and the product must not have been disassembled or modified without prior written authorization by Xantrex.

Proof of purchase may be in any one of the following forms:

- The dated purchase receipt from the original purchase of the product at point of sale to the end user, or
- The dated dealer invoice or purchase receipt showing original equipment manufacturer (OEM) status, or
- The dated invoice or purchase receipt showing the product exchanged under warranty

What does this warranty not cover? This Limited Warranty does not cover normal wear and tear of the product or costs related to the removal, installation, or troubleshooting of the customer's electrical systems. This warranty does not apply to and Xantrex will not be responsible for any defect in or damage to :

- a) the product if it has been misused, neglected, improperly installed, physically damaged or altered, either internally or externally, or damaged from improper use or use in an unsuitable environment;
- b) the product if it has been subjected to fire, water, excessive corrosion, biological infestations, or input voltage that creates operating conditions beyond the maximum or minimum limits listed in the Xantrex product specifications including high input voltage from generators and lightning strikes;
- c) the product if repairs have been done to it other than by Xantrex or its authorized service centers (hereafter "ASCs");
- d) the product if it is used as a component part of a product expressly warranted by another manufacturer;
- e) the product if its original identification (trade-mark, serial number) markings have been defaced, altered, or removed.

DISCLAIMER OF WARRANTY

THIS LIMITED WARRANTY IS THE SOLE AND EXCLUSIVE WARRANTY PROVIDED BY XANTREX IN CONNECTION WITH YOUR XANTREX PRODUCT AND IS, WHERE PERMITTED BY LAW, IN LIEU OF ALL OTHER WARRANTIES, CONDITIONS, GUARANTEES, REPRESENTATIONS, OBLIGATIONS AND LIABILITIES, EXPRESS OR IMPLIED, STATUTORY OR OTHERWISE IN CONNECTION WITH THE PRODUCT, HOWEVER ARISING (WHETHER BY CONTRACT, TORT, NEGLIGENCE, PRINCIPLES OF MANUFACTURER'S LIABILITY, OPERATION OF LAW, CONDUCT, STATEMENT OR OTHERWISE), INCLUDING WITHOUT RESTRICTION ANY IMPLIED WARRANTY OR CONDITION OF QUALITY, MERCHANTABILITY OR FITNESS FOR A PARTICULAR PURPOSE. ANY IMPLIED WARRANTY OF MERCHANTABILITY OR FITNESS FOR A PARTICULAR PURPOSE TO THE EXTENT REQUIRED UNDER APPLICABLE LAW TO APPLY TO THE PRODUCT SHALL BE LIMITED IN DURATION TO THE PERIOD STIPULATED UNDER THIS LIMITED WARRANTY.

IN NO EVENT WILL XANTREX BE LIABLE FOR ANY SPECIAL, INDIRECT, INCIDENTAL OR CONSEQUENTIAL DAMAGES, LOSSES, COSTS OR EXPENSES HOWEVER ARISING WHETHER IN CONTRACT OR TORT INCLUDING WITHOUT RESTRICTION ANY ECONOMIC LOSSES OF ANY KIND, ANY LOSS OR DAMAGE TO PROPERTY, ANY PERSONAL INJURY, ANY DAMAGE OR INJURY ARISING FROM OR AS A RESULT OF MISUSE OR ABUSE, OR THE INCORRECT INSTALLATION, INTEGRATION OR OPERATION OF THE PRODUCT.

Exclusions If this product is a consumer product purchased in the United States, federal law does not allow an exclusion of implied warranties. To the extent you are entitled to implied warranties under federal law, to the extent permitted by applicable law they are limited to the duration of this Limited Warranty. Some states do not allow limitations or exclusions on implied warranties or on the duration of an implied warranty or on the limitation or exclusion of incidental or consequential damages, so the above limitation(s) or exclusion(s) may not apply to you. This Limited Warranty gives you specific legal rights. You may have other rights which may vary depending on the country, province, or state.

WITHOUT LIMITING THE GENERALITY OF THE FOREGOING, UNLESS SPECIFICALLY AGREED TO BY IT IN WRITING, XANTREX

- (a) MAKES NO WARRANTY AS TO THE ACCURACY, SUFFICIENCY OR SUITABILITY OF ANY TECHNICAL OR OTHER INFORMATION PROVIDED IN MANUALS OR OTHER DOCUMENTATION PROVIDED BY IT IN CONNECTION WITH THE PRODUCT; AND
- (b) ASSUMES NO RESPONSIBILITY OR LIABILITY FOR LOSSES, DAMAGES, COSTS OR EXPENSES, WHETHER SPECIAL, DIRECT, INDIRECT, CONSEQUENTIAL OR INCIDENTAL, WHICH MIGHT ARISE OUT OF THE USE OF SUCH INFORMATION.

THE USE OF ANY SUCH INFORMATION WILL BE ENTIRELY AT THE USER'S RISK.

WARNING: LIMITATIONS ON USE

Please refer to your product user manual for limitations on uses of the product. Specifically, please note that the Xantrex Battery Charger is not intended for use in connection with life support systems and Xantrex makes no warranty or representation in connection with any use of the product for such purposes.

Xantrex Technology, Inc.
8999 Nelson Way
Burnaby, British Columbia
Canada
V5A 4B5

Return Material Authorization Policy

If your product requires warranty service, please contact your dealer first. If you are unable to contact your dealer, or your dealer is unable to provide service, contact Xantrex.

Before returning a product directly to Xantrex you must obtain a Return Material Authorization (RMA) number and the correct factory "Ship To" address. Product shipments will be refused and returned at your expense if they are unauthorized returned without an RMA number clearly marked on the outside of the shipping box, if they are shipped collect, or if they are shipped to the wrong location.

When you contact Xantrex to obtain service, please have your instruction manual ready for reference and be prepared to supply:

- The serial number of your product
- Information about the installation and use of the unit
- Information about the failure and/or reason for the return
- A copy of your dated proof of purchase

When you ship:

1. Package the unit safely, preferably using the original box and packing materials. Please ensure that your product is shipped fully insured in the original packaging or equivalent. This warranty will not apply where the product is damaged due to improper packaging.
2. Include the following:
 - The RMA number supplied by Xantrex Technology Inc clearly marked on the outside of the box.
 - A return address where the unit can be shipped. Post office boxes are not acceptable.
 - A contact telephone number where you can be reached during work hours
 - A brief description of the problem

Please contact Xantrex for details of the freight policy for your country of purchase. For United States and Canada returns, ship the unit prepaid to the address provided by your Xantrex customer service representative.

If you are returning a product to a Xantrex facility in North America from outside of the USA or Canada: In addition to the above, you **MUST** include return freight funds and are fully responsible for all documents, duties, tariffs, and deposits.

If you are returning a product to a Xantrex Authorized Service Center (ASC): A Xantrex return material authorization (RMA) number is not required. However, you must contact the ASC prior to returning the product or presenting the unit to verify any return procedures that may apply to that particular facility.

Information About Your System

As soon as you open your Xantrex XC3012, XC5012, XC1524 or XC2524 Battery Charger package, record the following information and be sure to keep your proof of purchase.

- Serial Number _____
- Purchased From _____
- Purchase Date _____

If you need to contact Customer Service, please record the following details before calling. This information will help our representatives give you better service.

- Type of installation _____
- Length of time charger has been installed _____
- Battery/battery bank size _____
- Battery type (e.g. flooded, sealed gel cell, AGM) _____
- DC wiring size and length _____
- Description of light indicators or remote display
readout _____
- Appliances operating when problem occurred _____
- Description of problem _____

Xantrex Technology Inc.

Phone: 1 800 670 0707 (toll free North America)
+34 93 470 5330 (Europe)
1 360 925 5097 (direct and rest of world)

Fax: 1-800 994 7828 (toll free North America)
+34 93 473 6093 (Europe)
1 360 925 5143 (direct and rest of world)

Email: customerservice@xantrex.com (North America)
support.europe@xantrex.com (Europe)
customerservice@xantrex.com (rest of world)