



DC-POWERCONVERSION

BATTERY SEPARATOR WITH MICROPROCESSOR

The solution

The Battery Separator is designed for use in situations where 2 batteries are used; for example in boats, campers and caravans. The Battery separator is a microprocessor controlled heavy duty relay that automatically connects batteries in parallel when one of them has reached a present voltage for at least 5 seconds (13,2V/26,4V) (indicating that the battery is being charged), and disconnects when the voltage decreases below float level for at least 5 seconds (12,8V/25,6V) (indicating that one or more batteries are being discharged). The Battery Separator is an excellent alternative to a battery isolators. The main feature is that there is virtually on voltage loss so that the output voltage of alternators or batterychargers does not need to be increased. Another advantage is that the Battery Separator can be mounted without changing the existing circuit. That makes the Battery Separator not only very easy to install, but is sometimes the only option because some alternators do not accept a Battery Isolator between itself and the the battery.

Priority

In a circuit with the Battery Separator the battery with the alternator (start battery) will be charged first before the second battery (auxiliary battery) will be connected. When a Battery Separator

senses that the starter battery has reached its connect voltage it will engage, to allow for parallel charging of the other batteries.

Bidirectional

The Battery Separator sensed the voltage of both connected batteries. It will therefore also engage if for example the auxiliary battery is being charged by a battery charger.

Parallel

The Battery Separator (BS 160 and BS 400) can also be engaged with a switch to connect batteries in parallel manually. This is especially useful in case of emergency when the starter battery is discharged or damaged.

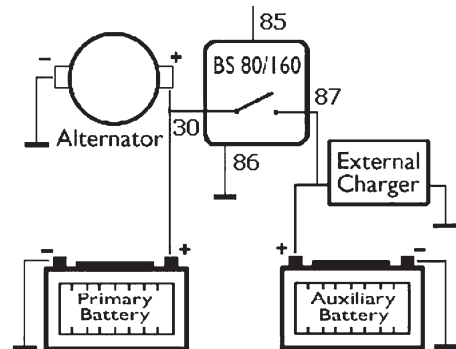

	BS 80/12	BS 80/24	BS 120/12	BS 120/24	BS 160/12	BS 160/24	BS 400/12	BS 400/24
Continues current (A)	80	80	120	120	160	160	400	400
Connect voltage (V)	13,2	26,4	13,2	26,4	13,2	26,4	13,2	26,4
Standby current	<5mA	<5mA	<5mA	<5mA	<5mA	<5mA	<5mA	<5mA
Start contact					yes	yes	yes	yes
Micro switch for remote status indication							yes	yes
Voltage stability	+/- 2%							
Weight Kgs	0,11	0,11	0,15	0,15	0,30	0,30	0,90	0,90
Dimensions (HxWxD in mm)	46x46x80	46x46x80	46x46x80	46x46x80	46x93x96	46x96x96	78x102x110	78x102x110

Standards: Emission
Immunity
Automotive directive

EN50081-1
EN50082-2
94/95CE

