



## Steca Tarom

### 235, 245, 440

The Steca Tarom is the high-end solar charge controller optimally designed for demanding telecom applications and complex off-grid PV hybrid system architectures. A huge variety of exiting features allows the user to adapt this controller to the special needs of the specific installation.

The optimised SOC calculation of Steca is implemented in the Tarom. It is your best choice for the medium and large power range (up to 2400 Wp) on three voltage levels (12 V, 24 V, 48 V). Additionally it is possible to connect further devices like a temperature sensor, a datalogger and a remote switch to configure and monitor the photovoltaic system optimally. A built-in Ah counter gives additional valuable energy balance information to the user.

### Features

- PWM shunt battery charging
- State of charge (SOC) battery regulation
- Energy management for hybrid systems
- Built-in Ah counter
- Boost-, Equalising-, Float charging
- Automatic load reconnection
- Automatic selection of voltage for 12 V / 24 V
- Temperature compensation
- Positive grounding (or) Negative grounding on one terminal
- Field adjustable parameters by four buttons
- Lighting control options during nighttime with PA 15
- RJ45 interface
- Manual load disconnect
- Optional: external temperature sensor

### Displays

- Two line LCD showing SOC, Vbat, all currents, Ah, alarms, charging procedure

### Certificates

- Listed for Worldbank funded projects in Nepal
- Conform to European Standards (CE)
- Made in Germany
- Manufactured in a DIN EN ISO 9001:2000 and DIN EN ISO 14001 facility

### Technical data

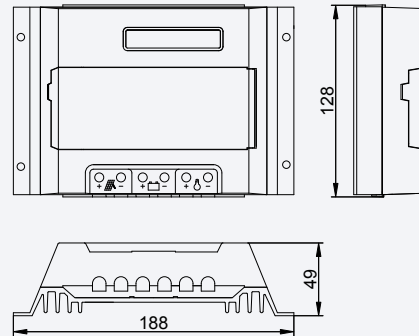

Solar Charge Controller	Tarom 235	Tarom 245	Tarom 440
System voltage	12 V (24 V)		48 V
Max. module input short circuit current	35 A	45 A	40 A
Max. load output current	35 A	45 A	40 A
Max. self consumption	14 mA		
programmable	End of charge voltage (float)	13.7 V (27.4 V)	54.8 V
	Boost charge voltage; 2 h	14.4 V (28.8 V)	57.6 V
	Equalisation charge (deactivated for gel accu); 2 h	14.7 V (29.4 V)	58.8 V
	Reconnection setpoint (SOC / LVR)	> 50 % / 12.6 V (25.2 V)	> 50 % / 50.4 V
Deep discharge protection (SOC / LVD)	< 30 % / 11.1 V (22.2 V)	< 30 % / 44.4 V	
Ambient temperature allowed	-10 °C...+60 °C		
Terminal size (fine / single wire)	16 mm <sup>2</sup> / 25 mm <sup>2</sup>		
Enclosure protection class	IP 22		
Weight	550 g		
Dimensions l x w x h	188 x 128 x 49 mm		

Technical data at 25 °C / 77 °F

### Power class

#### 30 A - 45 A

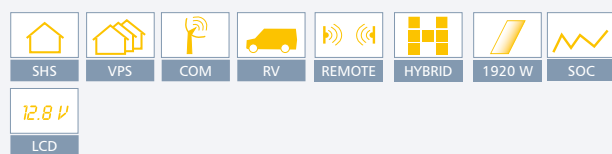

### Protection functionality

- High voltage disconnect (HVD)
- Low voltage disconnect (LVD)
- Dept of discharge disconnection (DOD)
- Reverse polarity of solar modules
- Reverse polarity of load and battery
- Short circuit of solar modules
- Short circuit of load
- Over temperature
- Over voltage
- Lightning protection by varistor
- Low electronic interference (EMC)
- Open circuit battery
- Reverse current at night