

Solarlink GmbH  
Drangstedter Str. 37  
D 27624 Bad Bederkesa

GERMANY

mail: [info@solarlink.de](mailto:info@solarlink.de)  
web: [www.solarlink.de](http://www.solarlink.de)

## Installation and Operation Instruction Manual



Solar Charging Controller  
8A / 12A / 20A / 30A

## Table of Contents

1	Safety precautions and Nonliability
2	Solar Charge Controller with Fuzzy-Logic
3	Configuration
4	Installation
5	Operation
6	Maintenance
7	Errors
8	Guarantee
9	Technical Data
10	Circuit Diagram

# 1 Safety Precautions and Nonliability

1.1 Safety Precautions are marked like that:

 Safety Precautions for the protection of persons are in bold print and marked with this symbol.

Safety precautions to be taken for the function of the system are bold print.

1.2 General Safety Precautions

For your own safety following points are to be noted:

 When wiring the controller do not reduce architectural measures for fire prevention. For details see 4.4 "System Wiring".

Do not install or operate PV-components in rooms, in which easy flammable gas mixtures can develop e.g. from gas cylinders, paints, lacquers, solvents!

Do not store these substances in rooms where PV-components are installed!

Avoid sparkings!

Solar modules produce current when light is falling in. Even at a small light infall the full voltage is applied. Therefore work carefully and pay attention to the corresponding safety precautions.

During assembly and installation in a direct current circuit of a PV-system voltages up to 50 V can arise. Therefore: Do not touch blank wire ends! Only use well insulated tools!

Do not use measuring equipment of which you know that it is damaged or defect!

The constructive safety precautions of the charge controller can be negatively be affected when it is operated in a way not specified by the manufacturer.

Any labels attached by the manufacturer must not be removed or made unrecognizable.

A restriction of the ventilation can lead to an overheating of the controller and thus to a failure. Do not cover ventilating slots and cooling ribs.

All works are to be executed in accordance with national and local regulations!

For an installation abroad the corresponding authorities are to be consulted.

Keep your children away from your PV-System!

1.3 How to use this manual:

This manual describes the functions and installation of a solar charge controller in a PV-system with a battery as storage.

For installation of other components e.g. solar modules and battery, please see the corresponding manual of the manufacturers.

Before you start read following:  
Installation of a controller 4.1 - 4.4

Make sure that all preparatory measures are taken.

Only start to install your controller when you are sure that you have understood this manual.

Only proceed in the order stated in this manual!

This manual has to be made accessible for third persons for all works done at the PV-system

This manual is part of the system controller and has to be passed over when it is sold.

1.4 Nonliability

The producer cannot survey the observation of this manual as well as the conditions and methods for installation, operation, use and maintenance of the system controller.

Improper installation can lead to material damage and thus can endanger persons.

Therefore we do not take any liability and responsibility for losses, damages and costs which are due to an improper installation, operation, use and maintenance or any other consequences.

Furthermore we do not take any liability for infringements of patent rights, or rights of third persons, which result from the use of

this system controller. The manufacturer reserves the right to make alterations without

# 2 System Controller with Fuzzy-Logic

prior notice concerning the product itself, technical data or the installation and instruction manual.

## 2.1 Overall functions of the controller in your PV-system

The controller is for use in PV-systems with battery storage in the field of leisure as well as in the living area, in smaller industrial systems.

The charge controller surveys the state of charge of the battery, controls the charging process as well as the switching on and off of the users. Thus the battery can be used optimally and its service life is prolonged considerably. The controllers are for use with lead accumulators with liquid electrolyte and can be adapted for use with other electrolytes. The controller can be used with all solar modules up to the maximum connection value of the module (safety factor according to 3.1-1-inclusive)

## 2.2 Control and regulative Functions

### • SOC Determination

By means of a new special algorithm the controller is able to "learn" the characteristics curve of the accumulator. After this phase of learning the state of charge (SOC) is displayed with medium accuracy of approx. 10 %. This state of charge is basis of most control and regulating functions.

### • Overcharge Protection

Frequent overcharging harms your battery. The charging process and the overcharge protection are therefore controlled by a new type of hybrid circuit with pulse width modulation in order to ensure a gentle charging of the battery.

### • Voltage recognition

By using a special measuring procedure accu sensor wires are no longer necessary. A voltage drop is compensated.

### • Cycle Charge (Lead/Gel)

When the SOC falls below 70% the final charge voltage is raised for 1 hour.

### • Equalization Charge (only Lead)

When the SOC falls below 40 % the equalization charging is activated. During this process the final charge voltage is raised for 1 hour, the electrolytes are mixed through and thus the service life of the battery is prolonged.

### • Monthly Charging

Depending on gel or lead accu, the

corresponding increase of the final charge voltage is maintained for one hour.

### • Temperature-Tracking of the final charge voltage

The ideal final charge voltage of lead accumulators falls with increasing battery temperature. A fixed final charge voltage leads to uncontrolled gassing by constant overcharging when higher battery temperatures are reached. The temperature tracking lowers the final charge voltage at high temperatures and raises the charge voltage at low temperatures. The temperature tracking with an integrated sensor is active during cycle and equalization charging. As a protective function of the users the final charge voltage is never increased over 15 V (e. g. equalization charge at low temperatures).

### • Displays

The operator is informed by two LED's about the operation status of your system. LED 1 (the Info LED) is for the controller's status, LED2 (SOC-LED) is for the battery.

### • Overdischarge Protection

Overdischarging leads to a capacity loss because of sulfation. The overdischarge protection switches off the users. When the SOC is higher than 50 % they are automatically reconnected.

## 2.3 Options

### • 16\*1 character LCD-Display

The most important system parameters are displayed on the optional LCD-display. During normal operation the display changes after 3 sec. to the next parameter. In the case of error it is shown what kind of error.

**Normal Operation:** Battery Voltage  
Voltage- and Status Display  Status Display

The display shows the accu voltage of the battery. The status display consists of 5 symbols. The first two symbols are internal control parameters. The first letter shows if the load disconnect is voltage "S" or SOC "L" controlled. The second letter shows if a lead acid "B" or a gel accu "G" is connected.

The last letter indicates if the controller is doing normal "N", cycle "G" or equalization "A" charge at the next cycle.

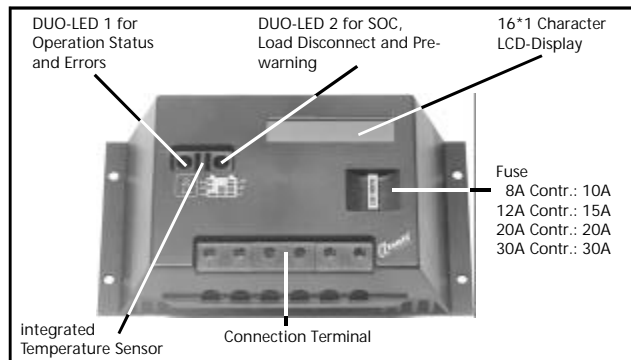

Illustration 1

### 3 Configuration

Display of SOC (State of Charge)



The SOC of the battery can be seen on a bar display. Each big bar is for 10 % SOC. The small bar is for additional 5 % SOC. (Above example is 75 % SOC).

Display of Charging Current



The bar display for load current shows the percentage of the nominal module current (this value is dependend from the power class of the controller) which flows into the accumulator. The evaluation is the same as for SOC.

Despite full sun infall no bar can be displayed when the accu is full and the module current is short circuited.



By an inverted sun symbol (see above) it is additionally displayed when no charge current flows at all (e. g. at night).

Display of Load Current



The bar display for load current shows how many percent of the nominal load current (dependend from the power class of the controller) flow into the users.

Display of Errors



In the case of an fault it is clearly displayed which error causes this fault. There are following error displays:

- load current
- modulcurrent
- overttemperature
- overtvoltage
- undervoltage

The controller is available with or without multimeter.

•Option PC-Connection

The connection for the LCD-display can also be used for connecting the controller with a PC. A connection kit with the appropriate software is available.

3.1 Adaption of the Controller

The solar charge controller adapts automatically to the system's voltage (12/24V) when it is installed.

The controller is in a state that it can be used for most cases without changes. It is only necessary to adapt the controller in following cases:

- use of a gel accu
- activation of nightlight function
- direct connection of a main user at the battery

Adaption is made by means of jumpers which can connect two neighbouring contact needles (see illustration 2).

Standard Setting:

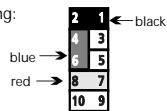

The controller is supplied with activated equalization charge i. e. it is ideal for batteries with liquid electrolyte. With other batteries the equalization charge is deactivated. Please see the regulations of the manufacturer.

**•Direct Connection with a Battery**

When the battery is connected with other chargers or a grid connect inverter the SOC display does not work. The controller can be adjusted to voltage orientated regulation. When the controller is adjusted to voltage-orientated regulation, the only criteria for SOC determination is the battery voltage. All functions are released by different voltage levels. This also applies for the SOC-display:

- LED<sub>red</sub> = 10.8 V = LCD<sub>0bars</sub>
- LED<sub>yellow</sub> = 12.0V = LCD<sub>3bars</sub>
- LED<sub>green</sub> = 13.2V = LCD<sub>10bars</sub>

In this status the SOC-LED only works as a colour multimeter.

Change the red jumper from 7/8 to 5/6. The blue jumper may not remain in standard position and has to be put into a new position according to article "Selection of Accumulator"

Example:  
Lead accu, direct connection to accu without nightlight function

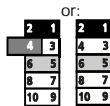

**• Selection of Accumulator**

Lead: Positon 3/4 may not be occupied. Either remove the blue jumper or place it on 4/6 (standard).

Gel: When gel accumulators are used the blue jumper has to be changed from 4/6 to 3/4.

**• Nightlight function**

When the controller is used with lighting systems the so-called nightlight function can be programmed. When this function is activated all users are connected at night and disconnected at daytime. The overdischarge protection is activated.

In order to activate the nightlight function the jumper which connects contact needle 1/2 has to be removed.

**Keep your jumpers safe so that the controller can again be reset to standard!**

**Possibility for storing, place jumper only on one pin:**

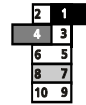

**When you are not sure that you are not able to configurate t h e controller yourself, do contact your dealer. There is no liability for any damages caused by incorrect adjusted controllers!**

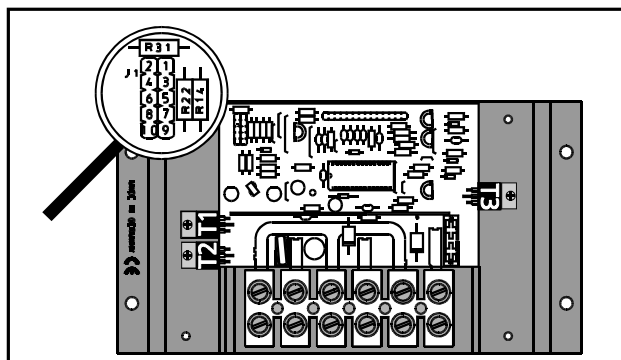
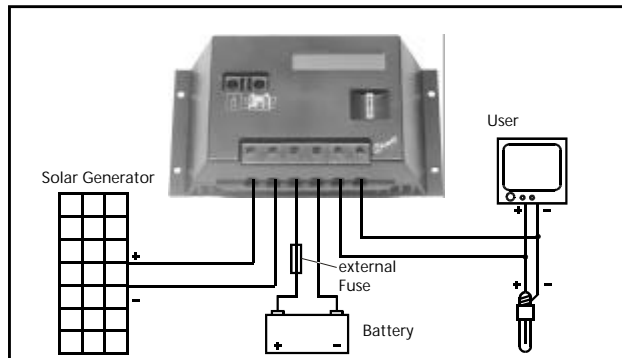

Illustration 2



## 4 Installation

### 4.1 Place of Installation:

**Do not install or operate PV components in rooms where easily flammable gases can develop!**

**Explosive gases can develop near the battery. Therefore avoid any sparking and see that the battery room is well ventilated!**

**Follow the regulations for batteries!**

**Also pay attention to:**

- DIN VDE 0510 part 2, section 7 Precautions against explosion danger, section 8 Precautions against dangers by electrolyte and 9 Place of Installation
- National Electric Code, including Article 690. The unit shall be installed according to this regulation.

Choose the place of installation according to following criteria:

- Shelter your controller from direct weather conditions
- Avoid direct sun light and heating caused by nearby devices
- Installation place as near as possible at the battery (safety distance at least 30 cm)
- See that there is no dirt or humidity

### 4.2 Attachment

Ensure ventilation of the dissipator:

- Install controller with cable openings downwards
- Keep a minimum safety distance of

100mm to devices above and below the controller

- Proper attachment: The controller is screwed on the wall through the holes at the enclosure (heat sink). The controller has no strain relieves, so that the cable diameters can be adapted to the local needs. Therefore strain relieves (e. g. cable clamps) are to be fixed approx. 100mm below the controller before the cables are distributed to the users.

### 4.3 Preparation of Wiring

Only use cables with an appropriate diameter for the power class of the controller. Following table gives the necessary minimum cable diameters for the cables between controller, module distribution box (in approx. 10m distance), the battery (approx. 1m) and the load distribution box (approx. 5m).

Controller	Diameter	AWG	Isolation
8A / 8A	6 mm <sup>2</sup>	10	85°C
12A / 12A	10 mm <sup>2</sup>	8	85°C
20A / 20A	10 mm <sup>2</sup>	8	85°C
30A / 30A	16 mm <sup>2</sup>	6	85°C

Also check if

- the battery to be used is suitable and if it is connected correctly (check voltage)
- the maximum solar current of the solar generator does not exceed the connection value of the controller

#### 4.4 Wiring

 **Solar modules produce current when light is falling in. Even at a small light infall the total voltage is applied. Cover your solar modules against light and fix it with a tape. By this means the modules can be installed without voltage.**

**The modules must not be short-circuited in order to ensure voltage-free operation!**

**Only use well insulated tools!**

**Never touch blank wire ends!**

**Each blank wire end which is not connected immediately is to be insulated at once!**

**All works are to be done only on a dry underground! Components (modules, cables etc.) may not get wet.**

**Pay attention to the correct polarity!**

##### Hints:

A grounding of the components in stand-alone systems is not necessary, not useful or can be prohibited by national regulations (e. g. DIN 57100 part 410 prohibition of the grounding of safety low voltage circuits). Further hints see point 10.

##### Confectioning:

Principally, all cables are confectioned before connection:

- Cutting to length
- Insulating both ends and fixing multicore cable ends
- covering of blank wire ends with insulating tape
- Mark every wire end:
  - Module Cable: M+, M-
  - Load Connection Cable: L+, L-
  - Accu Connection Cable: A+, A-

Connect module und phase wires in the sockets of the PV modules only according to the instructions of the manufacturer.

In order to rule out any failure the system components have to be wired in following order (battery, module, load):

1. Battery
2. Module
3. Load

##### Connection of the battery with the controller



- Remove fuse from the controller
- Lay Accu cable (A+, A-) between controller and battery parallelly
- Connect accu cable with connection terminal of the controller. Note correct polarity
- Attach external fuse\* at accu cable near accu terminal:
  - 8 A controller: 10 A
  - 12 A controller: 15 A
  - 20 A controller: 20 A
  - 30 A controller: 30 A

Do not insert fuse yet.

- connect accu cable A+ with battery-plus pole
  - connect battery cable A- with battery-minus pole
- \*) not included

##### Connection of the solar generator with the controller



- Connect module cable ends (M+, M-) with the controllers terminal. Note correct polarity.
- Only connect solar generators as energy source (no wind generator or fuel engine).

##### Connection of the users:



- Protect every user circuit by a fuse
- Before connection of the user cable switch off all users (remove fuse), in order to avoid sparking
- Connect user cable with terminal of controller. Note correct polarity.

Users which shall not be disconnected by the load disconnect (e. g. emergency lights, radio contact) may not be connected directly with the battery! Higher danger of overdischarge which is no longer controlled by the system controller! Protect these users by a separate fuse.

At last secure cables with pull relief near the controller. Also attach pull reliefs at all other components.

Table 1

	Error description	Protective-measures of controller	Information Display LED	Reset	Tech. Data
Normal Operation LCD	All OK	none	green flashing	no Reset	
Overcurrent Load LCD	load current is too high	Load is disconnected	red-green flashing load current	switch off or disconnect users 1), remove error, reconnect users	110%
Overcurrent Module LCD	module current is too high	Load is disconnected	modul current	automatically, when overcurrent does no longer exist 1)	110%
Over-temperature LCD	controller is overheated	Load is disconnected	red constant light overtemperatur	automatically, when temp. has decreased 2)	Innen-temp. 85°C
Over-voltage Battery LCD	battery voltage is too high	Load is disconnected; Module short circuited		automatically, when voltage has fallen 3)	15V
Under-voltage Battery LCD	battery voltage is too low; no accu or defect fuse	Load is disconnected	red flashing low voltage	automatically, when voltage has increased again	10.5V

1)The overcurrent disconnections are functions, which prevent the controller from destruction. When dimensioning your system, see that admissible module and load currents are not exceeded.

2) In case of an overheating, check if the controller is sufficiently cooled or ventilated at the installation place

3) A battery overvoltage can be caused by charging sources which are directly connected with the battery. The loads are disconnected as a precaution, as they are destroyed because of high voltages.

## 5 Operation

### 5.1 Operation

After wiring following points have to be checked:

- right polarity at all connections (cable marking)
- tightness of cable connections
- proper function of all pull reliefs
- parallel laying of accu cable
- tightness of screws and terminal connection
- insert fuse in controller and accu
- Remove cover from the solar module. The users only work when the right LED flashes fast or shines constantly

#### Putting system into operation

- Insert fuses at controller and battery
- remove cover of the solar generator

### 5.2 Operation Status Display

#### • Display of State of Charge (SOC)

The state of charge of the battery is indicated by the LED on the right which changes its colour in 10 levels from red (apprx. 0% SOC) via yellow (apprx. 50%) to green (100%).

#### • Overdischarge prewarning

When the SOC is lower than 40% the user is prewarned of a load disconnection by a fast flashing of the right LED (10 x faster than the left LED)

#### • Overdischarge Protection

A disconnection of the load by the overdischarge protection is shown by a slow flashing of the right LED. The load is disconnected when the SOC is 30% (red/yellow colour display). The load is automatically reconnected when the SOC is 50% (yellow colour display). The SOC can also be determined during the flashing by the colour of the LED.

#### • Information Display

The information display is flashing green during normal operation. As soon as a red colour tone can be seen there is an error. Table 1 shows which kind of error.

## 6 Maintenance

The controller is maintenance free. The complete PV system is to be checked at least once a year according to the specifications of the manufacturer.

- pull-reliefs and cable connections are to be checked
- screws are to be tightened up if necessary
- any dust or dirt is to be removed from the heat sink
- ventilation is to be ensured

The controller is protected from destruction

## 8 Guarantee

The manufacturer assumes following guarantees against end users:

The manufacturer repairs all manufacturing and material defects which show in the system controller during the period of warranty and which are limiting the functions of the controller. Natural signs of wear are no defects. There is no guarantee when the defect was caused by end users or third persons, especially by improper installation or operation, incorrect or careless handling, excessive use, poor structural work, unsuitable ground or inappropriate operation or use. There is only guarantee when the defect was immediately after discovery claimed by your dealer. The claim has to be addressed via your dealer. A copy of the receipt has to be enclosed.

A detailed description is necessary for a quick handling. After a period of 24 months after the purchase contract by the end user, there are no guarantee claims possible with the

## 7 Errors

by various measures. Nevertheless see that it is operated properly. Part of the errors is indicated by means of the Info LED. Only these errors can be shown which occur when the controller is correctly installed. Should other errors than described arise, please check first if the controller is connected with accu, module and users (load) at the correct polarity. Then check if the fuse is defect. In case of an error, the controller automatically switches off the load.

exception that the manufacturer agrees to a longer period specifically and in writing. The guarantee of the retailer, owing to the sales contract with the end user is not touched by this guarantee. Guarantee can be in the form of repairing or substitution. The cost for exchanging, sending or reinstallation are not included. Should repairing or substitution not be possible or are not within suitable time despite additional time by the customer, the deduction in value, caused by the defect is substituted or, when this is not enough for the end user, the contract will be annulled.

Further claims against the manufacturer owing to this guarantee declaration, especially claims for damages because of lower profit, damages for loss of use as well as indirect damages are excluded as far as there is no necessity of legal liability.

## 9 Technical Data

Solar Charge Controller Type	8 A	12 A	20 A	30 A
Max. Module Current at 50°C	8 A	12 A	20 A	30 A
Max. Load Current at 50 °C	8 A	12 A	20 A	30 A
Connection Terminal (fine/single wire)	16/25mm <sup>2</sup> = 4/6 AWG			
Weight	420 g			
Dimensions	188x106x49			
Protection	IP 22			
System Voltage	12/24 V			
Admissable ambient temperature	-25°C...+50°C			
Algorithm Data:	AtonIC			
	SOC orientated:	Voltage orientated:		
Prewarning:	SOC < 40 %	11,7 V		
Disconnection:	SOC < 30 %	11,1 V		
Reconnection:	SOC > 50 %	12,6 V		
Equalisation Charge (14,7 V)	SOC < 40 %	11,7 V		
Cycle Charge (14,4 V)	SOC < 70 %	12,4 V		
Final Charge Voltage	13,7 V	13,7 V		
Temperature Compensation	-4mV/K/Cell	-4mV/K/Cell		
Voltages have to be doubled for use in 24 V systems!				

## 10 Circuit Diagram

Following passages describe only the technical possibilities of a grounding. Aim is to maintain the controller's functions. National regulations of the operational area are to be adhered to by the electrician to do the installing. Loss of the safety low voltage status arising from grounding has to be compensated by corresponding insulation methods of active parts (protection against direct contact). When a grounding at the plus-side is chosen, it can also be taken as common mass for all system components. All plus connections are internally connected anyway. **See figure 2 on opposite page.**

Only one minus connection of the components module, accu and load can be grounded. When your solar system determines a minus mass (e. g. accu minus) only this component can be connected with this mass. A connection with further minus poles (module or load) bridges control elements and the fuse. This can lead to a malfunction and destruction of the controller. In systems with determined load-minus-mass (e. g. grounding of aeriels), all further components have to be connected floatingly. **See figure 1 on opposite page**