

## RUTLAND HRDX CHARGE CONTROLLER

The HRDX Controller incorporates the latest Pulse Width Modulation (PWM) technology to regulate charge to the battery. Windcharger and solar panel input and dual battery output features with a selectable LCD display gives complete battery management control for your renewable energy system.



- The PWM electronic charge regulator tapers charge to the battery to limit current and avoid battery overcharge. When regulating the Windcharger speed is reduced.
- Standard regulator cut in level is 13.8V and fully on at 14.4V for 12V systems (24V= 27.6V – 28.8V).
- Built in charge splitter for 2 isolated battery banks.
- 5 position switch for LCD digital display of:
  - ▶ Windcharger current
  - ▶ Solar current
  - ▶ Net charge current
  - ▶ Battery 1 voltage
  - ▶ Battery 2 voltage
- Charge source shutdown switch.
- Wall mounted.
- Designed for use with Rutland 503, 913 or FM910-3 plus up to 100w of solar panels.

LCD Display selector switch

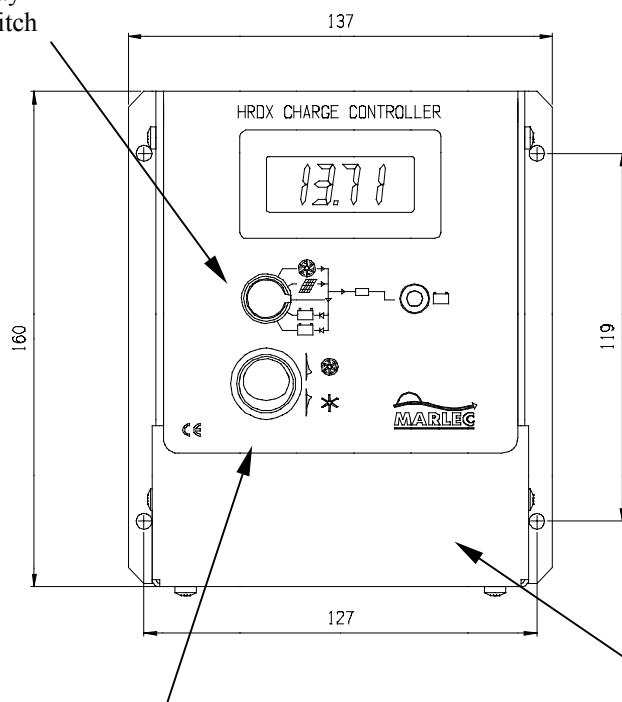

Shutdown Switch

Terminal access panel

Net weight: 0.85Kg

Carton weight: 0.97Kg  
Carton dims: 215x170x105mm



Marlec Engineering Co Ltd  
Rutland House, Trevithick Road  
Corby, Northants. NN17 5XY. UK

Tel: +44(0)1536 201588  
Fax: +44(0)1536 400211

sales@marlec.co.uk  
www.marlec.co.uk