

## M) TROUBLESHOOTING

- If errors occur during operation, try to correct them yourself first. The table below with the most common errors in handling and solutions will help you.

State	Possible cause
Nothing is working	- incorrect cable connection - insufficient voltage from the power supply - solar motor error - motor shaft blocked
Motor is turning too slowly	- incorrect cell fitting - too large load – too big – too heavy solar cell
Motor is following the sun with a delay	- wrong clock setting (repeat the procedure of clock synchronization)
Motor is not moving symmetrically to both extreme positions	- internal counters are not synchronized. Synchronization is automatically performed once a week. You can do it manually by the following procedure. Press any key (E or W) and turn off the battery and the solar cell while the motor is moving. When reconnected to the battery or the solar cell, the motor will synchronize its initial position. After the synchronization repeat the setting of the current time.

Dear buyer

If you have not managed to make the system work or you are having problems with the installation or you just have a message for us, you can contact us via:

- Skype or Windows Live Messenger web support on our website [www.solar-motors.com](http://www.solar-motors.com),
- call the technical assistance number printed on the first or last page, **+3864-281-6215**,
- or write to [support@solar-motors.com](mailto:support@solar-motors.com), where we will advise you about further steps.

If you have successfully set the system and you are satisfied, we congratulate you!

Your manufacturer Sat Control d.o.o.

**SunTracer OG and SunTracer OG+**  
with time-derived astronomical positioning for the automatic sun-tracking of the solar cell

## INSTRUCTIONS FOR INSTALLATION AND USE

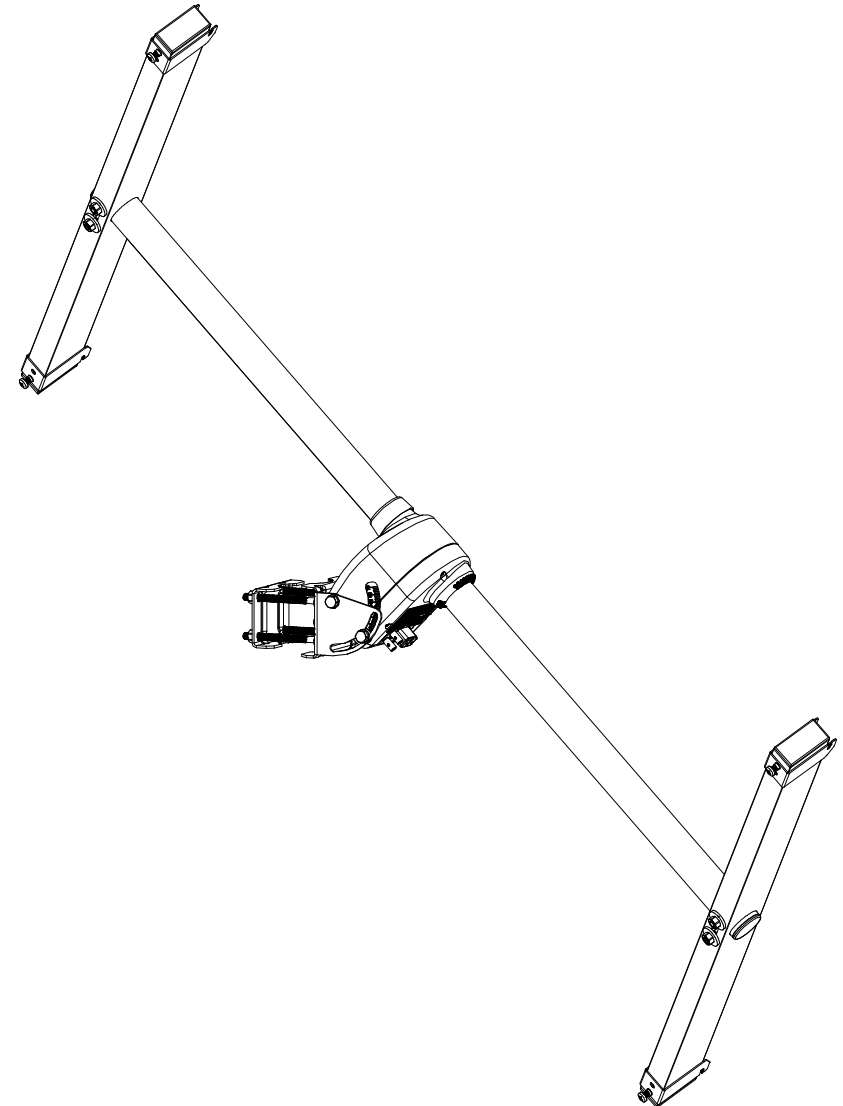

enter UTC manually in the next window (other names for UTC are Greenwich Mean Time – GMT, or Standard Time).

- **Note!** The mean solar time used by the solar motor is set for your geographical latitude, and differs from your zone time. Therefore, do not worry if it differs by a few minutes from your time zone clock.
- **»Azimuth, elevation«:** they show the clock angle and the elevation angle of the motor shaft. The clock angle has negative values in the morning, and positive values in the afternoon. The clock angle limits are from -50.0° to 50.0°. The »Elevation« value is only available for a dual-shaft motor version.
- **»Hposition, Hdestination, Vposition, Vdestination«:** they show the current and the destination positions of the clock angle and elevation measured in pulses. These values can only be used to diagnose the solar motor operation. The shaft's »Vposition« and »Vdestination« are only available for the dual-shaft solar motor.
- **»Hcurrent, Vcurrent«:** it measures the motor current for the solar motor's clock angle. This value is intended for diagnostic purposes. The »Vcurrent« detail is only available for a dual-shaft motor version.
- **»User's latitude«:** it means the geographical latitude; in the other input field, enter the hemisphere in which you are installing the solar motor. The geographical latitude is only available for the dual-shaft version of the solar motor, for which this value is required. But you can set the hemisphere: enter »n« for the northern hemisphere, and »s« for the southern hemisphere.
- **»Stator length«:** it means the initial position of the vertical axis when assembling the solar motor. This value is only applicable to the dual-shaft solar motor.
- **»Moving interval«:** it means at what interval the solar motor will correct its position to trace the sun. You can type in a time from 1 to 15 minutes, depending on the FW (firmware).
- **»Time controlled«:** it denotes whether automatic positioning will be enabled, or the position will be entered manually. Enter »y« for the solar motor to turn automatically according to the clock, or »n« if you wish the solar motor to turn using commands, by typing coordinate values in the »azimuth« input field.
- **Upgrade.** The control electronics (firmware) in the solar motor can be upgraded. If there exists a newer version than the one you are using, a message on the next page draws your attention to it. To do an upgrade, proceed as follows: Download both files offered to you by the browser in step 1 (see figure). To do this, left-click the link and select »Save link as«. Save both files to the same location, anywhere on your computer disk. Then, enter the path to the location where you have saved the files (to the file that has the extension EHX). Click the »Install« button to open the upgrade window. When the upgrade is finished, you will be able to use the new version. Note: Different safety precautions may be displayed. It is important that you allow the running of the »ActiveX« script.

### Update Section

1. Please download following files to the same directory...

[Download Update.exe](#)  
[Download Suntracer.ehx file](#)

2. Browse for \*.ehx file.

C:\update\suntracer\_27B1G.ehx

Browse

3. Click on "Install" button:

Install

**Note:**

In the case of any security warning about running ActiveX, you should allow it with pressing "Yes!"

# Solar tracking system monitor



Connect Your SunTracer to the COM port, select COM Port, and press "Connect" button!

SunTracer Type:  COM Port:    
 SunTracer Version:

U <sub>supply</sub> :	<input type="text" value="13.2"/> V	<input type="button" value="Send"/>		
Time:	<input type="text" value="10"/> h <input type="text" value="45"/> <input type="text" value="26"/>	<input type="button" value="Send"/>		
Day/Month/Year:	<input type="text" value="1"/> <input type="text" value="4"/> <input type="text" value="x"/> <input type="button" value="Synch."/>	<input type="button" value="Send"/>		
Azimuth:	<input type="text" value="-20.0"/> °	<input type="button" value="Send"/>	Elevation:	<input type="text" value="x"/> ° <input type="button" value="Send"/>
H Position:	<input type="text" value="1783"/> imp.	<input type="button" value="Send"/>	V Position:	<input type="text" value="x"/> imp. <input type="button" value="Send"/>
H Destination:	<input type="text" value="1785"/> imp.	<input type="button" value="Send"/>	V Destination:	<input type="text" value="x"/> imp. <input type="button" value="Send"/>
H Current:	<input type="text" value="1"/> mA	<input type="button" value="Send"/>	V Current:	<input type="text" value="x"/> mA <input type="button" value="Send"/>
Users's latitude:	<input type="text" value="x"/> ° N	<input type="button" value="Send"/>		
Stator length:	<input type="text" value="x"/> mm	<input type="button" value="Send"/>		
Moving interval:	<input type="text" value="5"/> sec.	<input type="button" value="Send"/>		
Time controlled:	<input type="text" value="y"/>	<input type="button" value="Send"/>		

- Each **white** input field displays the current value, i.e., the solar motor setting. Clicking in a particular input field turns the field **yellow**, which means you can change its value. As long as the input field is yellow, you can enter a new value in it. When you are satisfied with the new value, press »Enter« or click the »Send« button. The entered value will be sent to the solar motor, the input field will turn white again, and will show the new (changed) current value.
- Some input fields are only intended to show the values and can not be changed (for example: supply voltage display). In such fields, a change will not take effect.
- EXPLANATION OF THE MEANING OF THE DISPLAY FIELDS AND INPUT FIELDS
- »U<sub>supply</sub>«: current supply voltage connected to the solar motor.
- »Time«: current solar time (for your location). By entering new values, you can change the current time. The possible hour range is 0-23, and the minutes range is 0-60.
- »Day/month/year«: current date. By entering new values, you can change the current date. The range for days is 1-31, and for months 1-12. The year can only be entered (and displayed) on a dual-shaft motor version.
- Pressing the »Synch.« button automatically sets the current time and date. If your time or date is wrong (by more than half an hour), press the »Synch.« button to open a window for the input of your geographical latitude. Enter the latitude, and confirm it. The Web application connected to the internet calculates the coordinated universal time (UTC), and writes it in the solar motor memory as the **mean solar time** for your location. If you are not connected to the internet, you will have to

## CHARACTERISTICS OF THE SOLAR MOTOR SunTracer OG & SunTracer OG+

- New-generation, professional motor with integrated astronomical time positioning, and structural background for the automated sun-tracing of the solar cell
- Robust aluminium housing with a strong symmetric metal shaft
- Polar-mount construction for an ideal single-shaft tracing of the solar circle
- Motor turning up to 100°, which means almost 7 hours of perpendicular tracing of the sun
- For solar cells up to 2m<sup>2</sup>, and/or up to 200Wp (depending on the model)
- Low energy consumption for its operation
- Integrated RS232 communication interface for the control and setting of the parameters, program upgrade and external computer control
- Simple synchronization with the solar time
- Back-up battery for internal clock and date
- Practical in tropical and desert conditions
- Made in Slovenia (EU)

### Technical data:

Horizontal turning	98° typically (100° max.)
Inclination (motor elevation)	75°
Accuracy of tracing	<0.5°
Shaft diameter	Ø40 mm (steel)
Final stage of cogwheel	steel worm wheel
Turning speed	1.33°/s ±25% @17V & @100W solar cell & @-10°C
Motor supply	from 10 to 45VDC
Power consumption in idle state	20 mA ±25% @ 12V
Consumption during operation (with a 50 W solar cell)	<200 mA ±25% @ 50W solar cell
Initial current consumption	350 mA @ t < 0.25s typically
Operating temperature	-25°C to +70°C
Operating humidity	0% to 100% of relative humidity
Connection	2 cables with an internal Cu conductor of 1.0mm <sup>2</sup>
EAST-WEST limit	end switches, programmable limit
Turning time interval	1 minute
Maximum working torque of output shaft	35.9 Nm @17V & @0.5°/s (measured)
Destructive torque of output shaft	>200 Nm
Estimated service life	20,000 turns of 180° (90°E + 90°W) or 10 years

### Application

- Individual power-supply systems for huts, houses or cottages.
- Smaller solar power plants on building roofs.
- Bigger solar power plants set up on larger areas.

### Technical data for SunTracer OG

- Arm width: 0.6m
- Motor shaft length: 560mm
- Max dimen. of a solar cell: 1m x 0.6m of aluminium structure, made for panels with up to 0.6m<sup>2</sup> in area
- Max. solar cell weight: 10kg, on condition that the solar cell is turning through the centre of gravity
- Dimensions of a packed motor: 590(L) x 135(W) x 170(H)mm +590(L) x 135(W) x 35(H)mm
- Product weight: 6kg
- Max. safe wind speed: <160km/h

- **Technical data for SunTracer OG+**

- Arm width: 1m
- Motor shaft length: 1,150mm
- Max dimen. of a solar cell: 2m x 1m of aluminium structure, made for panels with up to 2.0m<sup>2</sup> in area
- Max. solar cell weight: 25kg, on condition that the solar cell is turning through the centre of gravity
- Dimensions of a packed motor: 1175 (L) x 135 (W) x 200 (H) mm
- Product weight: 8kg
- Max. safe wind speed: <130km/h

## A) PACKAGE CONTENTS AND NECESSARY TOOLS

• The SunTracer solar motor package consists of: (component parts are shown in the following figure).

- |                                    |   |
|------------------------------------|---|
| 1. Holder clamp / (1 piece)        | 9. U-bolt M8 / (2 pieces)                     |
| 2. Clamp screw / (2 pieces)        | 10. Holder arm / (2 pieces)                   |
| 3. Fixing clamp / (1 piece)        | 11. Washer M8 – wide / (4 pieces)             |
| 4. Washer M8 / (4 pieces)          | 12. Nut M8 / (4 pieces)                       |
| 5. Nut M8 / (4 pieces)             | 13. Clamp, solar / (4 pieces)                 |
| 6. SunTracer OG+ motor / (1 piece) | 14. Screw M6x12 / (4 pieces)                  |
| 7. Washer M8 / (4 pieces)          | 15. RS232 communication cable with DB9-M con. |
| 8. Screw M8 / (4 pieces)           | 16. Instructions for installation and use     |

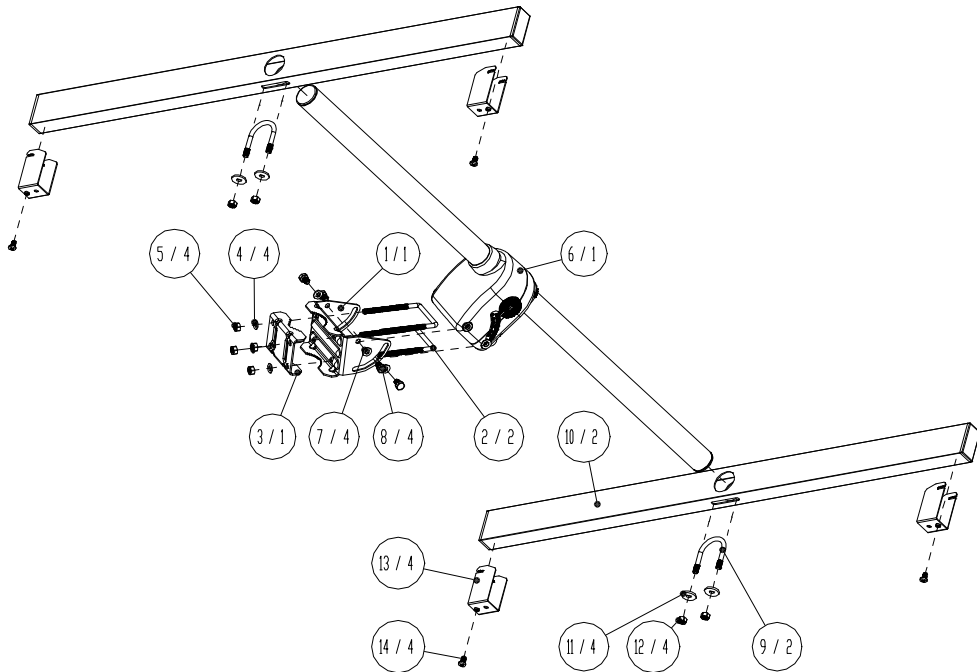

- **Note!** The mean solar time used by the motor is set for your geographical latitude, and may differ from your zone time. Therefore, do not worry if you have saved the solar time in the motor at a really ideal perpendicularity of the cell to the sun, while you see in the menu of the motor on the computer that the saved time is not the same as the actual time on your watch. This is especially obvious if your country uses winter and summer time, where the summer time is moved an hour forward.

## L) ADDITIONAL FUNCTIONS BY CONNECTING TO A PC

- The basic motor operation is not conditioned by the use of a PC.
- However, it provides additional functions that can be useful for advanced users. In addition, different current values of the solar motor can be seen in the menu.
- **ATTENTION!!** Changing the values in the menu may influence the solar motor operation!
- Connect your PC to the motor using the enclosed communication cable. Use the serial COM port on your computer. If your PC does not have this port, you can use the RS232-USB interface.
- On the computer, open the Internet Explorer browser, which is part of the Windows environment. Other browsers or operating systems are not supported for the time being. Type » [www.sat-control.si/monitor](http://www.sat-control.si/monitor) « in the address bar. If you do not have access to the internet at the location of the solar motor, an offline version ([www.solar-motors.com](http://www.solar-motors.com)) is available on our website.
- When opening the website, the browser will warn you that it has restricted the running of the ActiveX script for security reasons. Since the ActiveX script is of key importance, it must be enabled. Click on the row where the warning appeared, and select Allow Blocked Content.



- We declare that the active content of the ActiveX script located on our website will not harm your computer, and is only intended for communication with the SunTracer motor.
- If your browser has high security settings and the ActiveX script will not start, you will have to change the security settings. To do this, go to the »Tools« menu, »Internet Options«, »Security«, and in the »Internet« frame enable all the items referring to ActiveX. Contact us if you have any problems.
- All you have to do is select the correct serial COM port. Clicking the »Connect« button should display values in the input fields.

- Motor during operation.

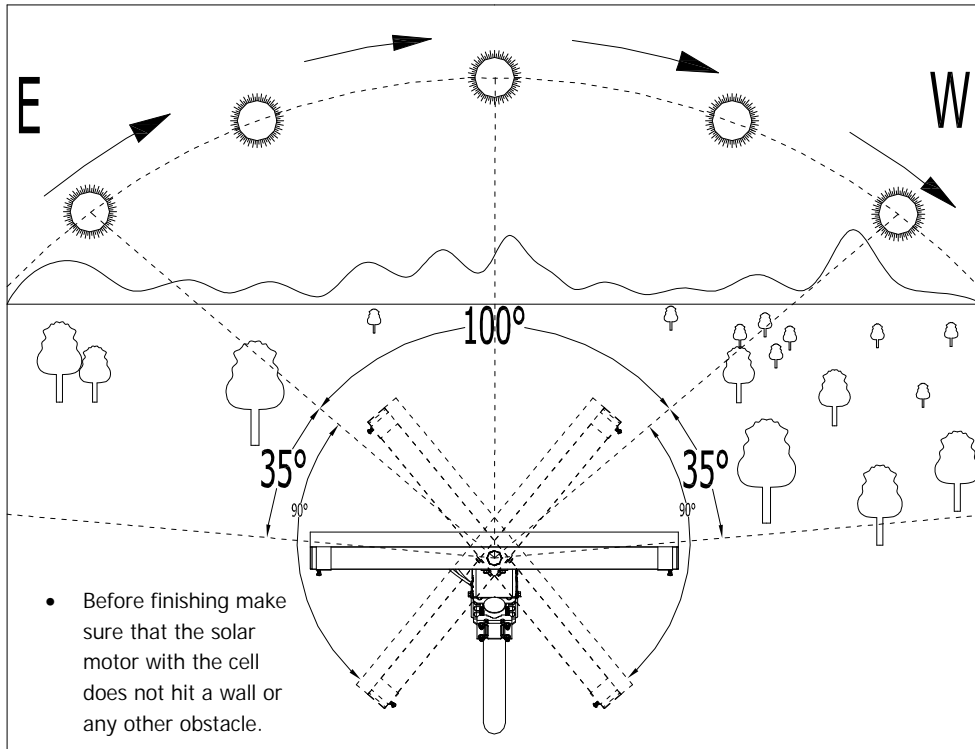

- When connected the motor started turning to the extreme East, to the initial position. With the WEST and EAST keys you turn the motor to the West and East. When you set the panel perpendicularly to the sun, press both keys at the same time and hold them for at least 5 seconds. From that time on the motor will automatically follow the sun. There is a detailed description in the following section.
- Now you have performed the mechanical and the electrical part of the installation. You can proceed to the synchronization to the solar time for your location. There is a detailed description in the next step.
- By doing so you have finished the installation.

### K) SYNCHRONIZATION TO THE SOLAR TIME

- The solar motor will follow the sun correctly if the internal clock of the motor is synchronized with the mean solar time. This can be done in a simple way. Between 9 o'clock in the morning and 15 o'clock in the afternoon (of the solar time) by pressing appropriate integrated keys on the motor, turn the motor shaft electrically (press the appropriate E / W key) so that the solar cell is as perpendicular to the sun as possible. For this you can use a rectangle which you place perpendicularly on the cell and look for the smallest shade made by the perpendicular side. When you have found and/or reached the best perpendicularity of the fall of the sun rays, press and hold both keys at the same time for 5 seconds. After 5 seconds the green LED indicator will light up for a short time and in this way warn you that the solar time is saved. From then on the motor will follow the sun correctly, since its internal clock is set to your mean solar time.

- To fit the SunTracer OG+ motor and the solar cell to an already set pole you need:
- Measuring tape
- Fork wrench, size 13 mm
- Flat and a cross screwdriver, size #2
- Socket wrench, 1.5 mm
- For cable preparation: knife and clips
- Bubble level
- A compass for determining the south, a voltmeter, an ammeter, a hammer, and a drilling machine

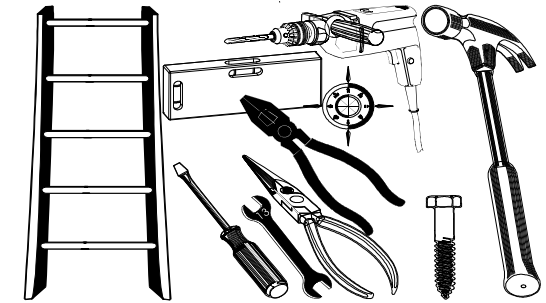

**Attention: The package does not contain electrical connection cables or connectors, a wall holder or any other holder, and a solar cell. These are mentioned here just to provide a full description of the fitting. \* - They are only enclosed in the package in exceptional cases, since they are enclosed to the solar cell.**

### B) DESCRIPTION

- You have in front of you a small, but efficient SunTracer OG+ motor for turning the solar cell. This is a device that turns the solar cell always perpendicularly to the fall of the sun rays and in this way enables the highest whole-day utilization of the solar cell. The solar cell gives the highest output power if it is turned as perpendicularly as possible to the source of radiation – the sun. Any other illumination angle of the rays reduces the output power of electricity that can be obtained from the cell. Therefore, it is sensible to use a sun-tracing system and in this way obtain up to 62% more electricity on a sunny day than you would otherwise. Electricity consumption of the motor itself for the turning is negligible compared to the profit.
- Control is fully automated. According to the internal clock, the motor corrects its position at adjustable time intervals and in this way traces the sun. The area of motor motion is about 100 degrees, therefore the motor starts tracing the sun at 8:40 solar hours and stops at 15:30 solar hours. Outside this time the motor is at a standstill, except at 23 hours, when it turns to its initial position and in this way waits for the sun in the East.
- With precise fitting you can achieve that the motor ensures the perpendicular tracing of the sun by the solar cell throughout 100 degrees.
- In normal, average conditions the motor works with any solar cell up to 0.6m<sup>2</sup> and/or 2m<sup>2</sup>, depending on the model. The solar cell should not be too heavy, exposed to hurricanes or large quantities of wet snow. In addition to the weight, when choosing a larger solar cell you have to be especially careful that fixing to the motor shaft is done as close as possible to the solar cell surface and you have to ensure that the solar cell is fitted as close as possible to the centre of gravity. If all of these conditions are fulfilled, the motor will work flawlessly even with a solar cell with the largest possible surface, as indicated in the instructions for a particular model.
- The internal clock will run even if there is no energy. This is taken care of by the internal back-up battery (3V lithium battery).
- The motor can also be fitted to an existing pole on the roof or to a wall holder with an as short as possible horizontal handle.

### C) SAFETY PRECAUTIONS

Do not open or "repair" the SunTracer motor by yourself! Leave this task to the authorized service! Unprofessionally assembled motor can cause a **fall** of the solar cell, possibly together with the motor!

Since poor fixing of motor and/or poor construction of the solar cell fixing can cause the solar cell to slip from the motor shaft during use or, for example, the screws holding the pole to be pulled out, you have to pay particular attention to that during fitting. In addition to the appropriate tightening of the screws, such an installation place has to be chosen that no lives or things are threatened in case of loosening of the screws or unhinging of the solar cell!



### D) GLOSSARY

- **Elevation** – vertical angle under which you »see« the Sun from the Earth.
- **Azimuth** – angle between the North and the projection of the direction of the sun on a plane.
- **Clock angle** – angle between the direction of the sun and noontime.
- **E in W** – abbreviations for East and West.
- **Motor pole** – straight rotating metal axis to which you attach the arms for the solar cell.
- **Solar cell** – this is a photovoltaic element that turns the light – sun energy into electrical energy. It must be installed in open space so that it is perpendicularly illuminated.
- **Geographical longitude** – on an as accurate as possible map of your country, region or town find a mark – the value of a vertical line closest to your town.
- **Geographical latitude**: on a map of your country, region or town find a mark – the value of the horizontal line closest to your town (Oslo 60, London 51.5, Berlin 52.5, Munich 48, Paris 49, Ljubljana 46, Rome 42, Madrid 40.5, Ankara 40, Algiers 37, Cairo 30). The geographical latitude has to be determined with an accuracy of at least 2 degrees.

### E) CHOICE OF THE INSTALLATION PLACE

- During the installation avoid as much as possible the possibility of the solar cell threatening or damaging people or things in case of possible fall (unhinging).
- The motor is watertight, so the solar cell can be installed on the roof or on the ground. Keep in mind that rain, hail and even more snow and wind make the turning of the solar cell more difficult. In addition, be careful about possible obstacles that could hinder the sight of the sun in the whole area of turning and/or ensure an installation place in which the solar cell will be illuminated by the sun from the sunrise to the sunset. In this way you will profit the most from the solar cell.

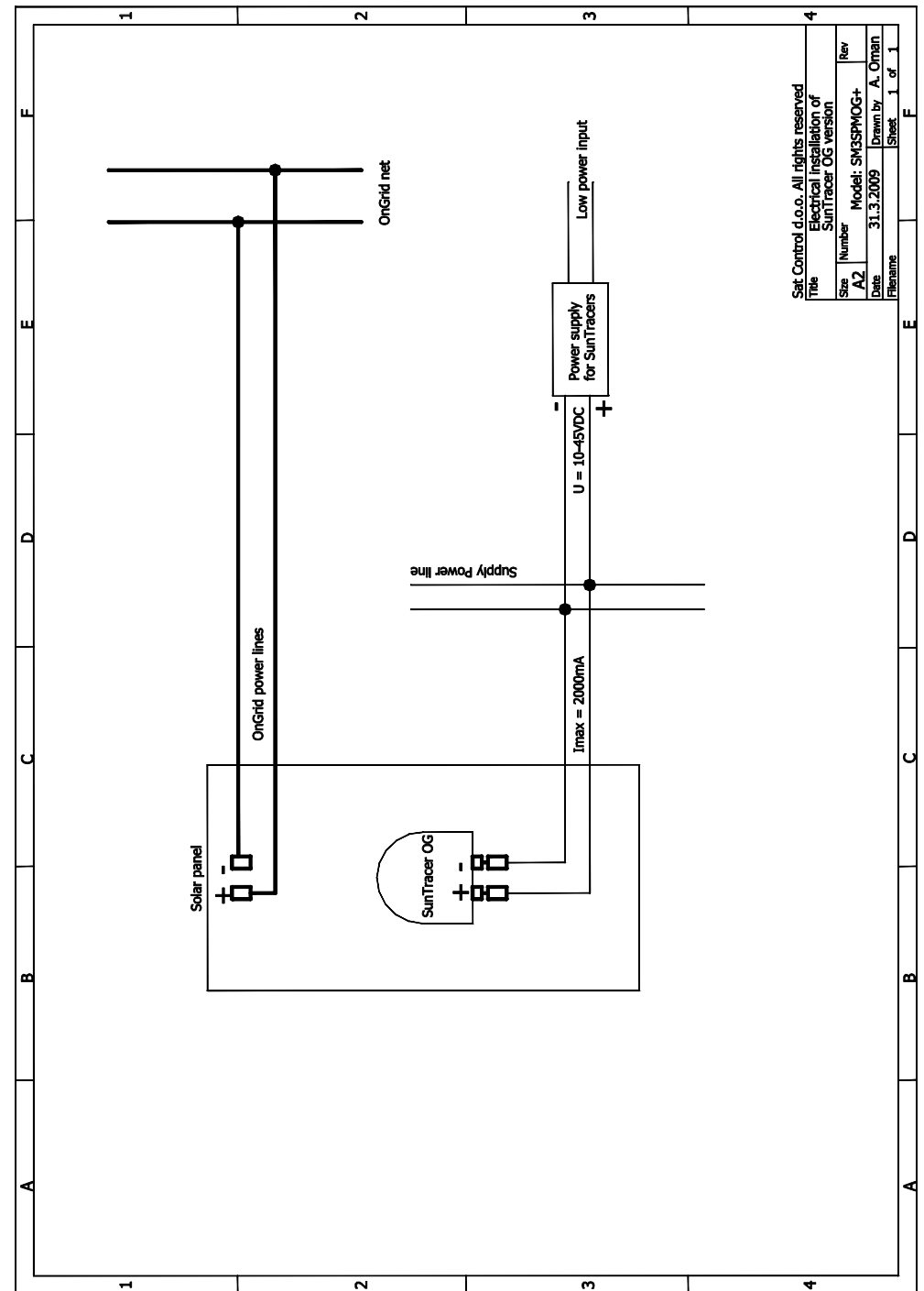

Sat Control d.o.o. All rights reserved	
Title: Electrical installation of SunTracer OG version	
Size: A2	Rev: 1
Number: 31.3.2009	Model: SM3SPMOG+
Date: 31.3.2009	Drawn by: A. Oman
Filename:	Sheet: 1 of 1

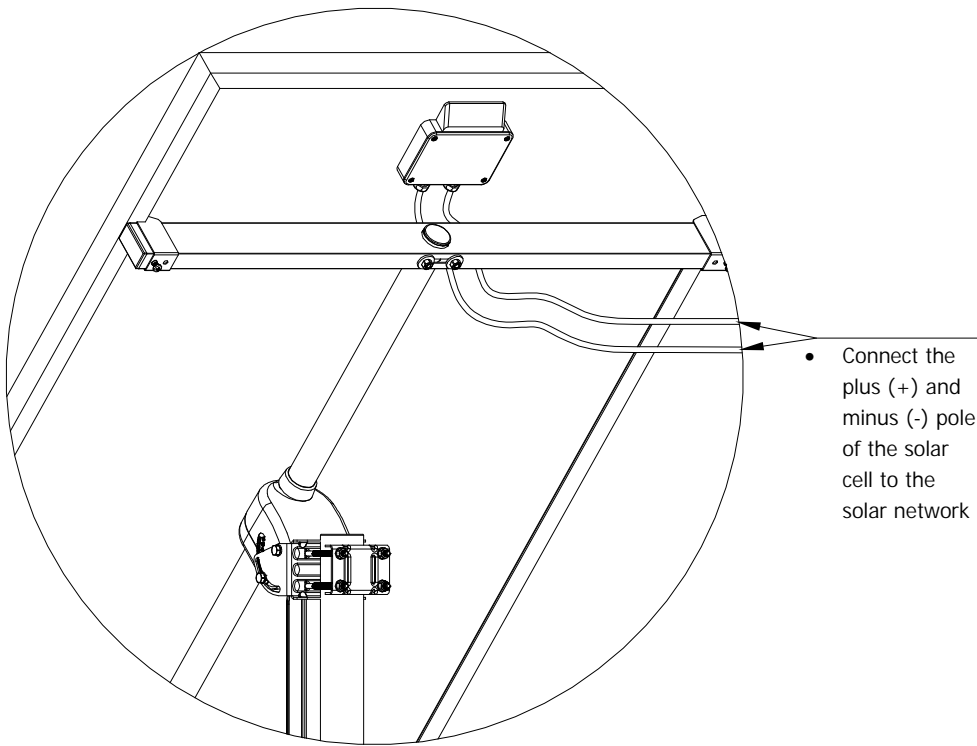

- Connect the plus (+) and minus (-) pole of the solar cell to the solar network

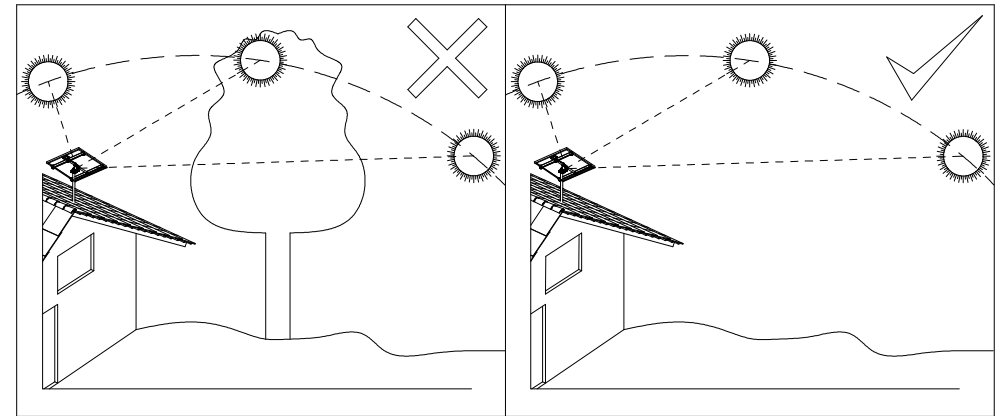
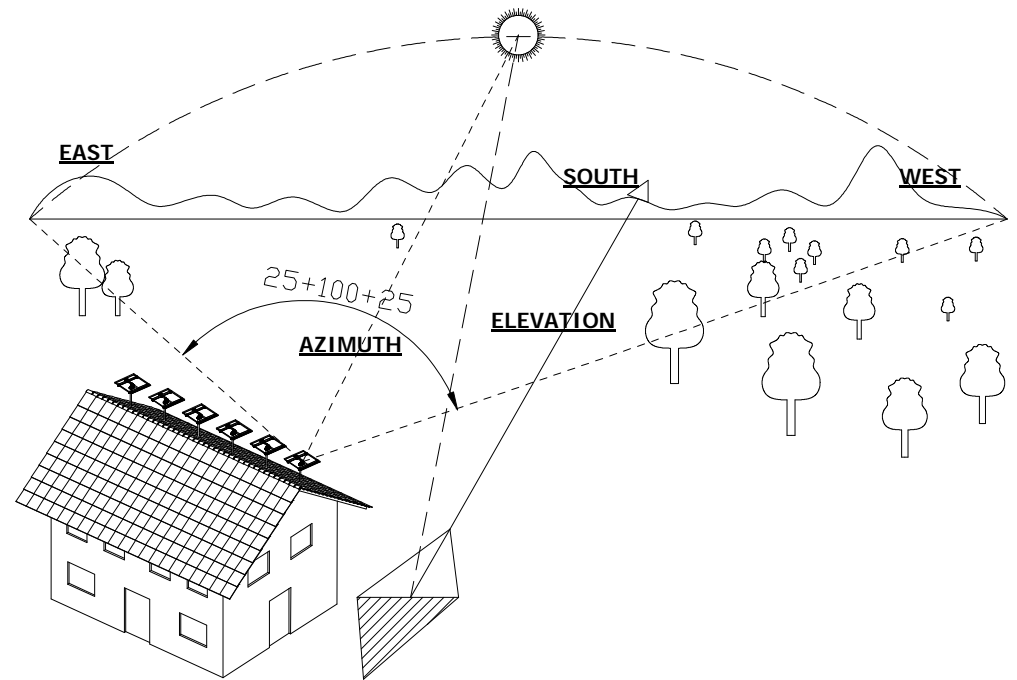

**F) PREPARING CONNECTION CABLES**

- In order to connect the SunTracer+ solar motor with the power-supply unit or the power distribution unit, you need a pair of solar cables with a cross-section of 1mm<sup>2</sup> or more, and appropriate length.
- 1. Strip the end of the cable, about 8 mm.
- 2. Insert the stripped cable into the contact opening until it stops, then tighten the socket-head screw on the connector. Pay attention to the polarity. Do not tighten the screw too much or else you can punch the conductor.

## G) MOTOR ASSEMBLY

- Assemble the SunTracer OG+ solar motor according to the sequence shown in the following picture.
- The first number shows the sequence of assembling the parts, and the second one how many parts need to be assembled.

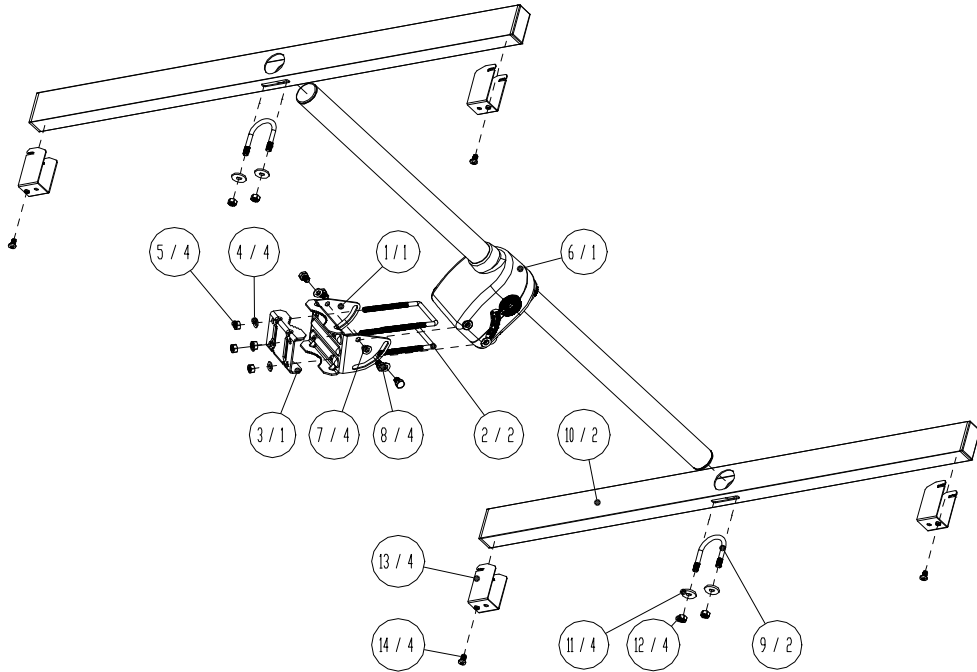

## J) CONNECTION WITH CABLES, AND ATTACHMENT

- Connect the cables as shown in the picture, and attach.

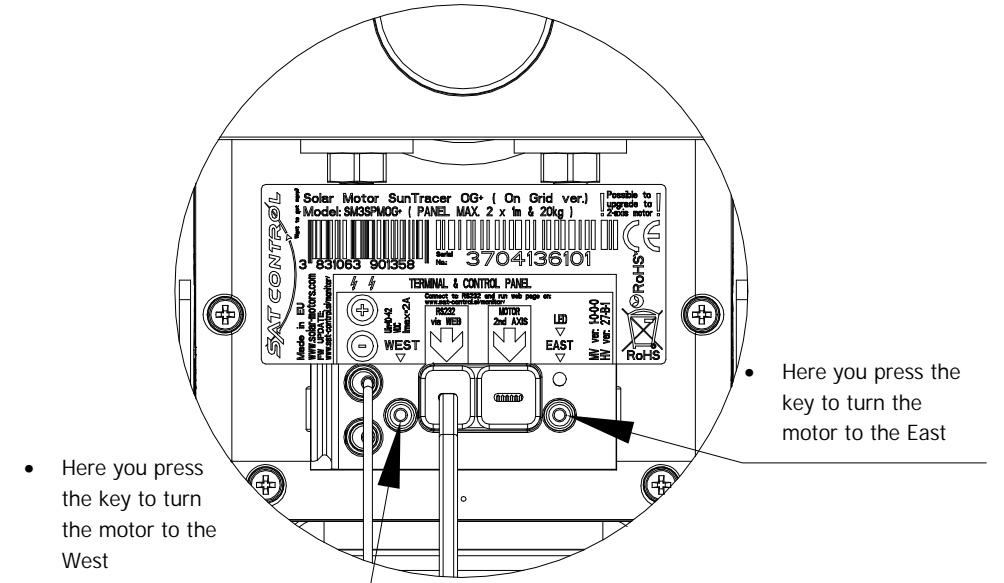
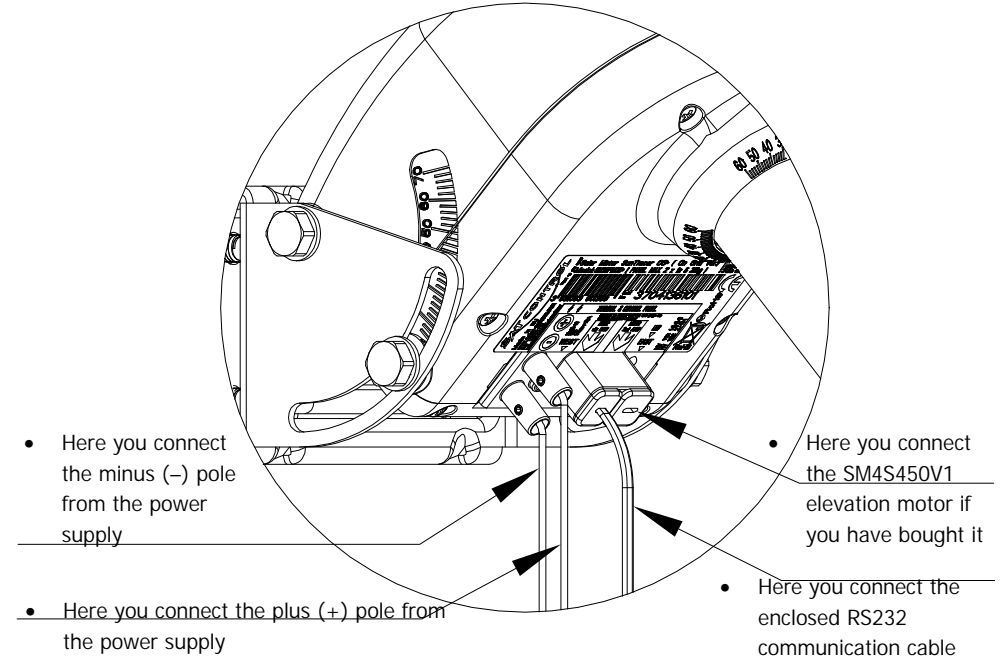

- Detail of solar cell fitting by scissor clamps onto holder arms.

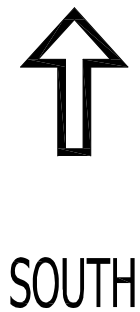
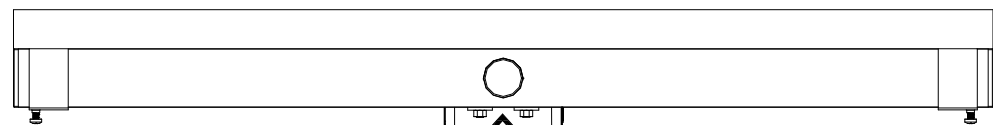
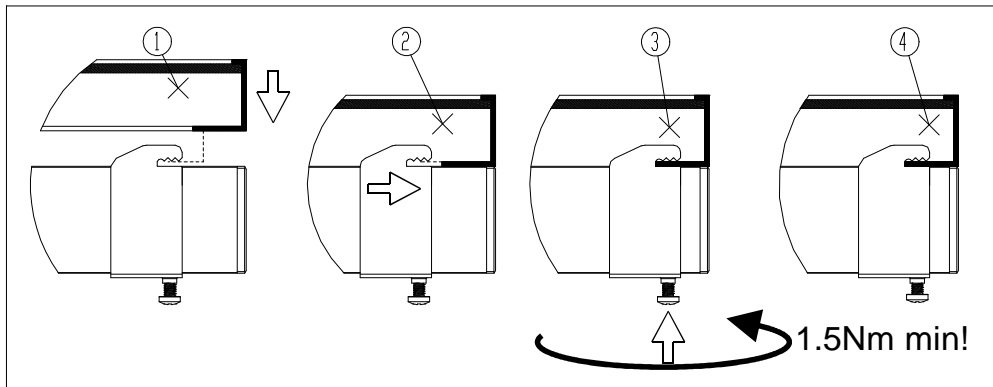

- Make sure that the pole or the wall holder is vertical.

90°

- Normally tighten the screws on the motor clamp so that you do not bend the clamp and the screws do not loosen due to the force of wind on the solar cell.
- If you have followed the instructions correctly, the motor with the solar cell is standing on the pole facing South. Now you just need to carefully connect the cables to the solar cell and to the battery as described in the following step.

- - When assembled, this is the way it looks:

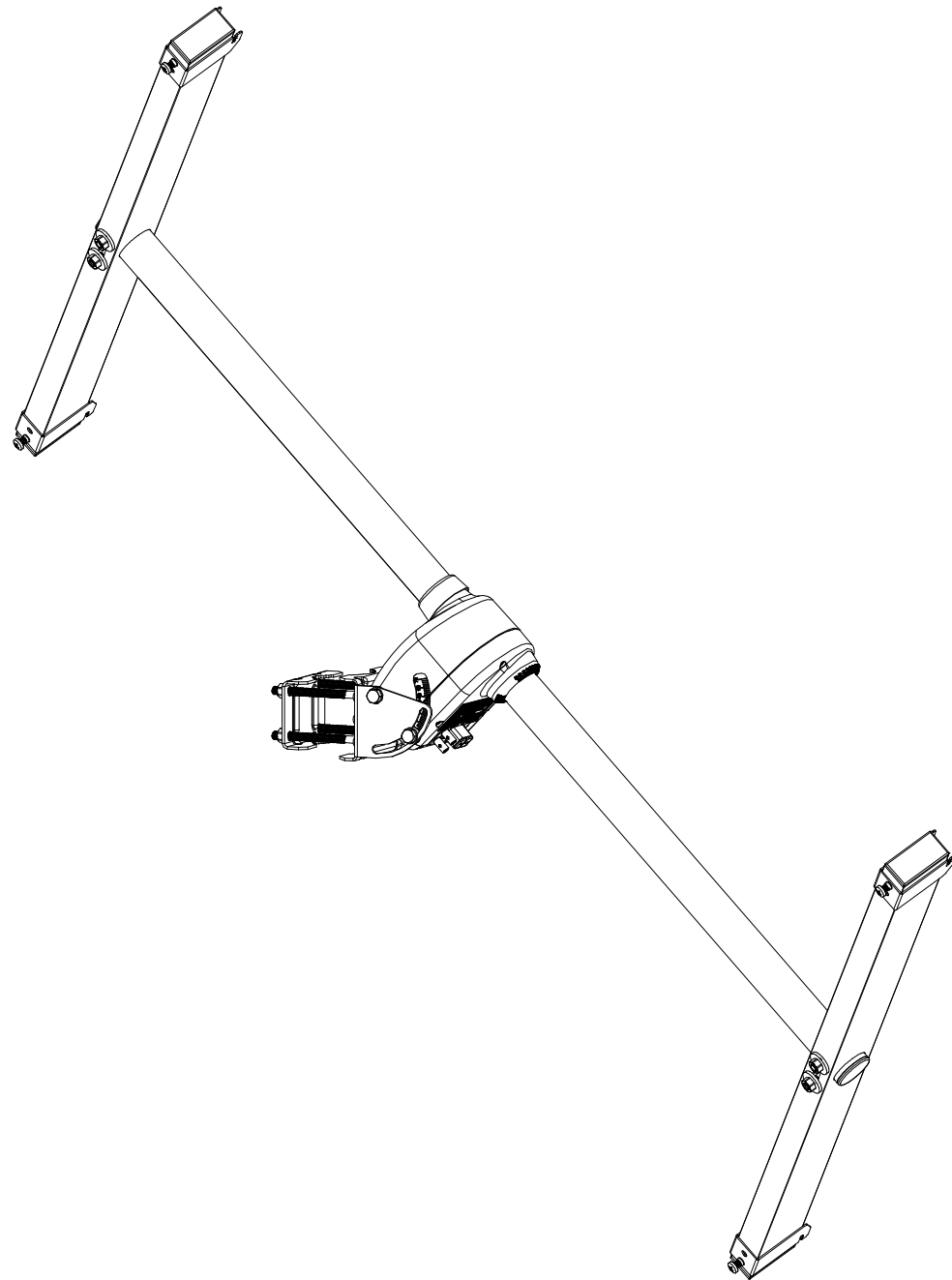

## H) SETTING THE MOTOR CLAMP SCALE

- Set the motor clamp to the angle that corresponds to your geographical latitude. The latitude in degrees is a direct setting on the motor clamp (X°). Example: for Paris with the latitude of 49° it is 49°.
- In the winter time (December), when the inclination of the Earth changes up to 23.5° to the North, the inclination or elevation of the motor can be reduced by up to 23.5°. In the summer time (June), when the inclination of the Earth changes up to 23.5° to the South, it can be increased by up to 23.5° from your latitude.
- Inclination or elevation of the motor has to be set so that the sun light always falls perpendicularly on the solar cell. It changes in different seasons. Thus, the motor elevation can be corrected several times a year.
- We recommend that in the winter time the motor elevation is set to the following value: your latitude - 15°, and in the summer time to your latitude + 15°. In between it should be set to the value of your latitude. See figure.
- The screws for the fixing of the clamp to the motor have to be screwed tightly, since there are standard metal nuts in the motor.

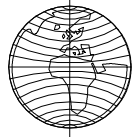
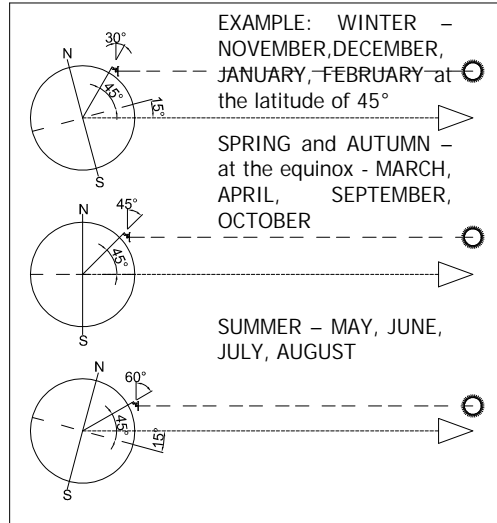

- G.L. and +15° or -15° according to the season



- SET TO THE CALCULATED ANGLE
- FOR EXAMPLE: 45°

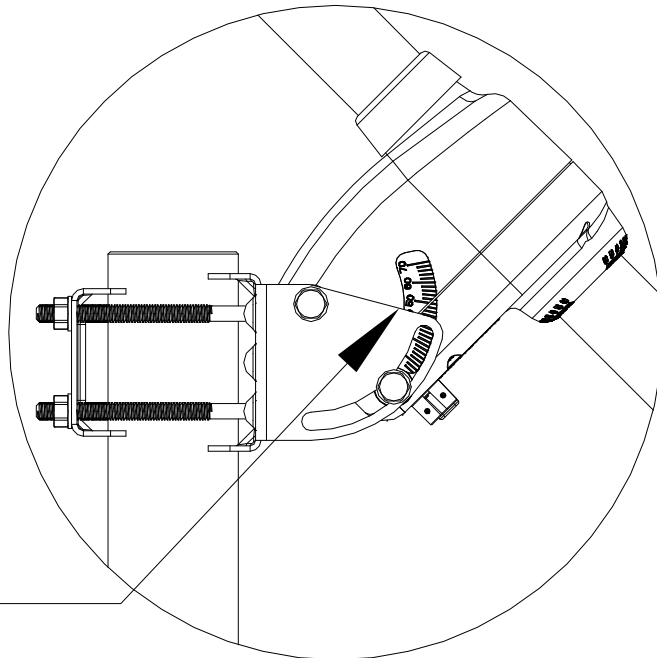

## I) INSTALLATION OF THE MOTOR TO THE POLE AND SOLAR CELL TO THE MOTOR SHAFT, AND MOTOR ORIENTATION TO THE SOUTH

- Turn the assembled SunTracer+ solar motor to the South and install it onto a vertical pole. Then install the solar cell onto it in the way shown in the following figures.

