

NOTES: UNLESS OTHERWISE SPECIFIED

1. SEE DRAWING NO. CB-00295 AND PROCEDURE P-1000 FOR ASSEMBLY AND TEST INSTRUCTION. PROCEDURES AND ASSEMBLY DRAWINGS ARE FOR INTERNAL USE ONLY.
2. ALL TESTING ARE IAW BATTERY COUNCIL INTERNATIONAL STANDARDS.
3. ALL DIMENSIONS ARE IN INCHES [MM].

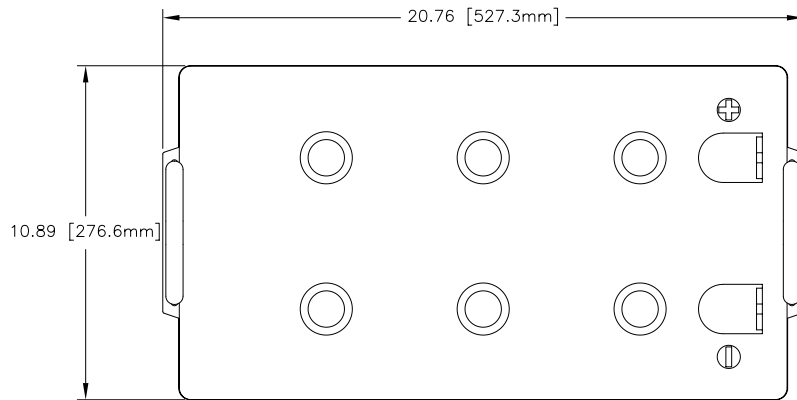

GPL-8D TERMINAL OPTIONS

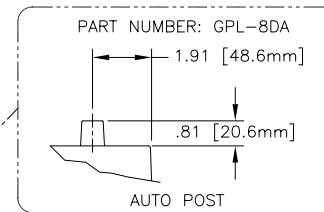
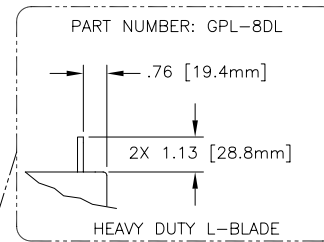

NOTE: SEE OPTIONS LISTED

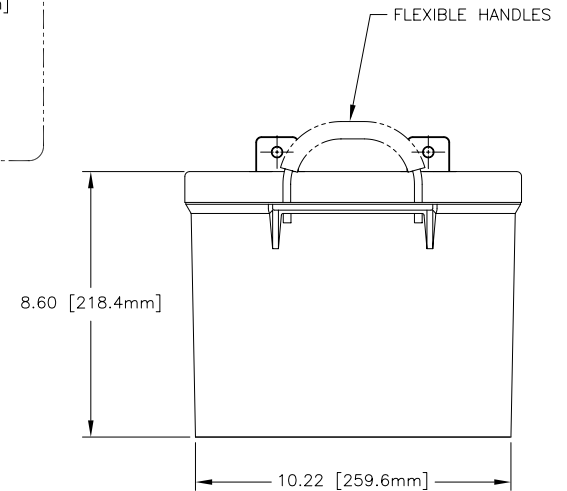
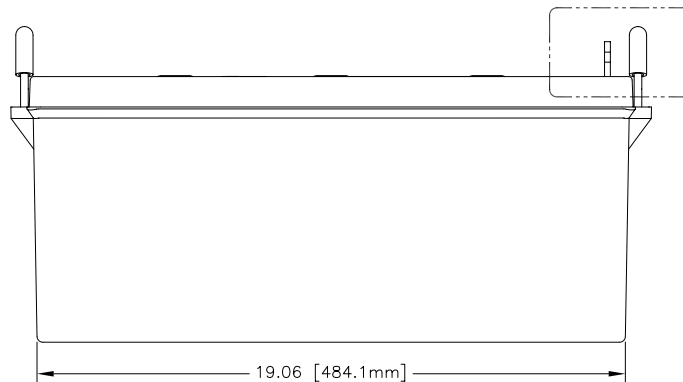

REVISIONS			
REV	DESCRIPTION	DATE	APPROVED
A	PRODUCTION RELEASE	5/5/94	DG
B	SEE DCN 0187	4/15/97	DG
C	SEE DCN 0267	2/12/98	JBT
D	ADDED TERMINAL OPTIONS	9/16/99	DG
E	REV. RATING TABLE, DEL. GPL-8DS, ADDED NOTES	3/23/00	DG
F	REDESIGNED CONTAINER, COVER	4/2/02	JBT
G	ADDED AUTO POST OPTION, 1.13 WAS 1.05	4/3/04	JBT

Solarlink GmbH
 Drangstedter Str. 37
 D 27624 Bad Bederkesa
 GERMANY
 e-mail: info@solarlink.de
 web: www.solarlink.de

ENVELOPE DRAWING

CAPACITY RATINGS	
PART NUMBER	GPL-8D
NOMINAL WEIGHT	162 LBS[73.6 KG]
AMPERE HOUR CAPACITY @ 20 HOUR 1.75 VOLTS/CELL @ 77°F (25° C)	255 AH
MINUTES OF DISCHARGE @ 25 AMPS 1.75 VOLTS/CELL @ 77°F (25° C)	475 MIN

QTY	REQD	CAGE CODE	PART OR IDENTIFYING NO.	NOMENCLATURE OR DESCRIPTION	MATERIAL SPECIFICATION	ITEM NO.
PARTS LIST						
UNLESS OTHERWISE SPECIFIED DIMENSIONS ARE IN INCHES TOLERANCES ARE:				CONCORDE BATTERY CORPORATION		
FRACTIONS .XX ± .06 ± 1"				2009 SAN BERNARDINO RD, W. COVINA, CA 91790		
DECIMALS .XXX ± .030				BATTERY, 12 VOLT, GPL-8D		
ANGLES				CONTRACT NO. N/A		
TREATMENT NONE				APPROVALS		
FINISH NONE				DRAWN TORRES J. DATE 5/9/94		
SIMILAR TO N/A				CHECKED JR 5/9/94		
ACT WT N/A				APPROVED DG 5/9/94		
CALC WT N/A				ISSUED AT 6/7/04		
SCALE NONE		SIZE C		CAGE CODE 63017		DWG NO. GPL-8D
SHEET 1		OF 1		REV G		REV G

ENGINEERING COPY 07JUN04