

NOTES: UNLESS OTHERWISE SPECIFIED

1. SEE DRAWING NO. CB-00288 AND PROCEDURE P-1000 FOR ASSEMBLY AND TEST INSTRUCTION. PROCEDURES AND ASSEMBLY DRAWINGS ARE FOR INTERNAL USE ONLY.
2. ALL TESTING ARE IAW BATTERY COUNCIL INTERNATIONAL STANDARDS.
3. ALL DIMENSIONS ARE IN INCHES [MM].

REVISIONS			
REV	DESCRIPTION	DATE	APPROVED
A	REMOVED SIDE HOLD-DOWNS	JBT	5/14/02

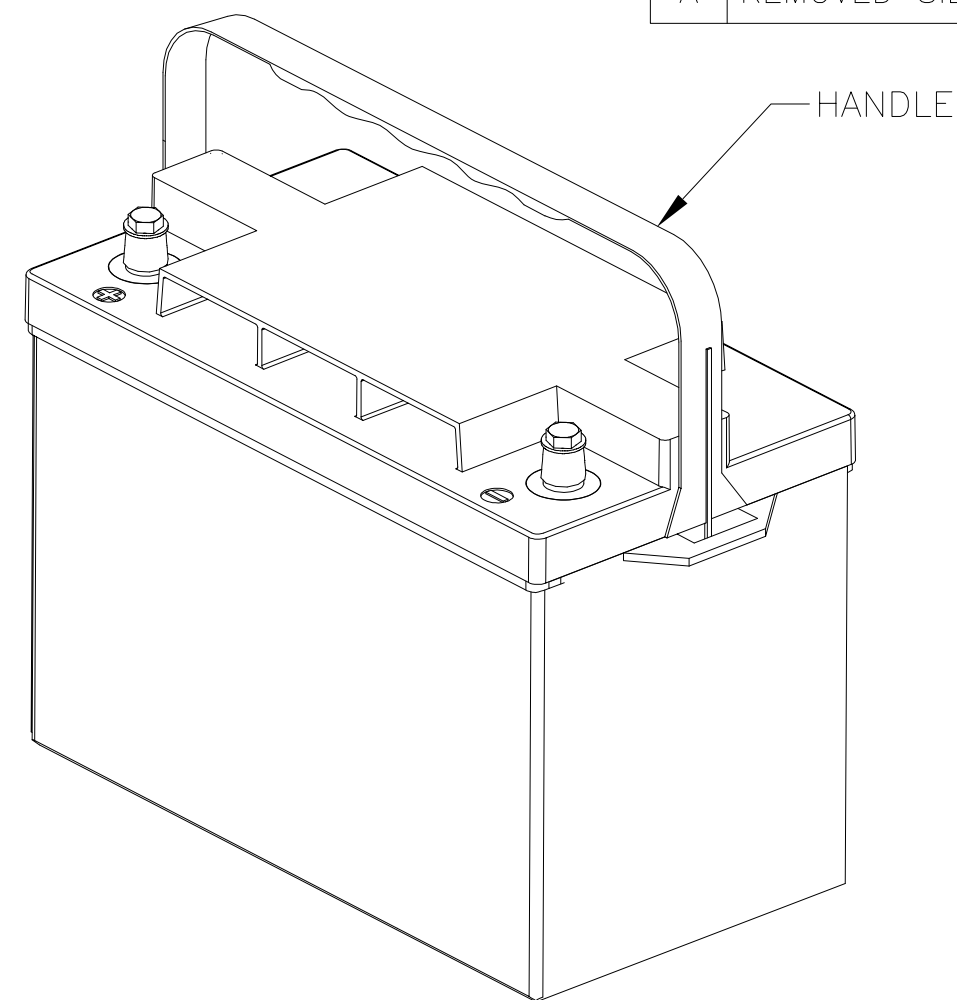
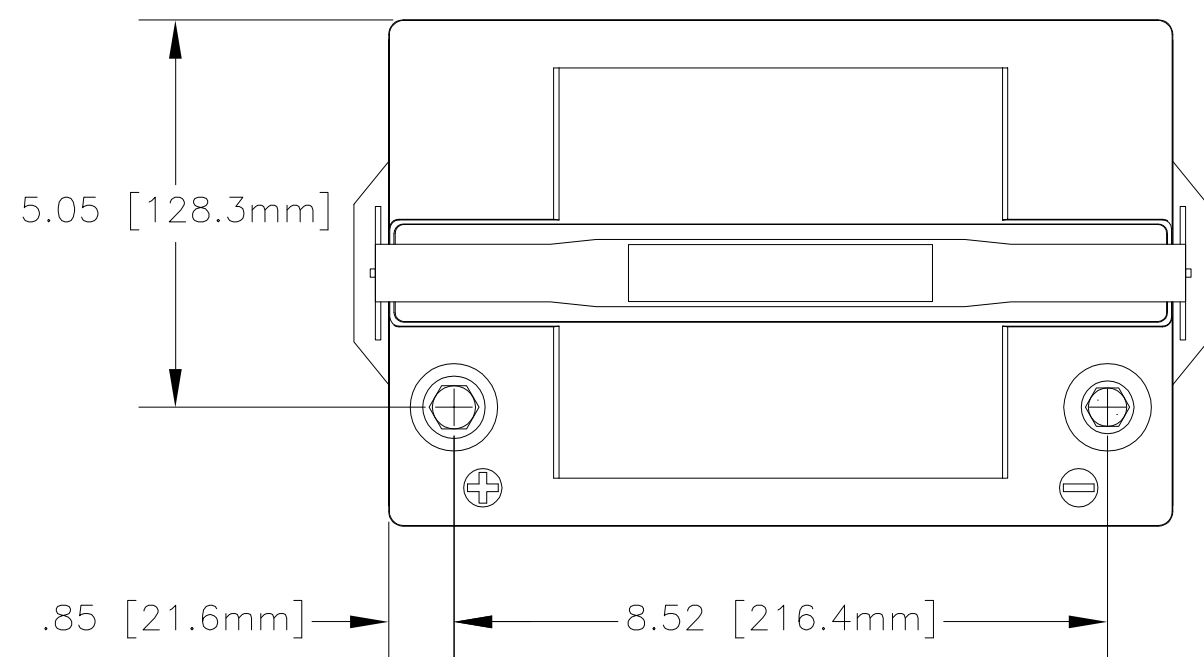

REFERENCE VIEW

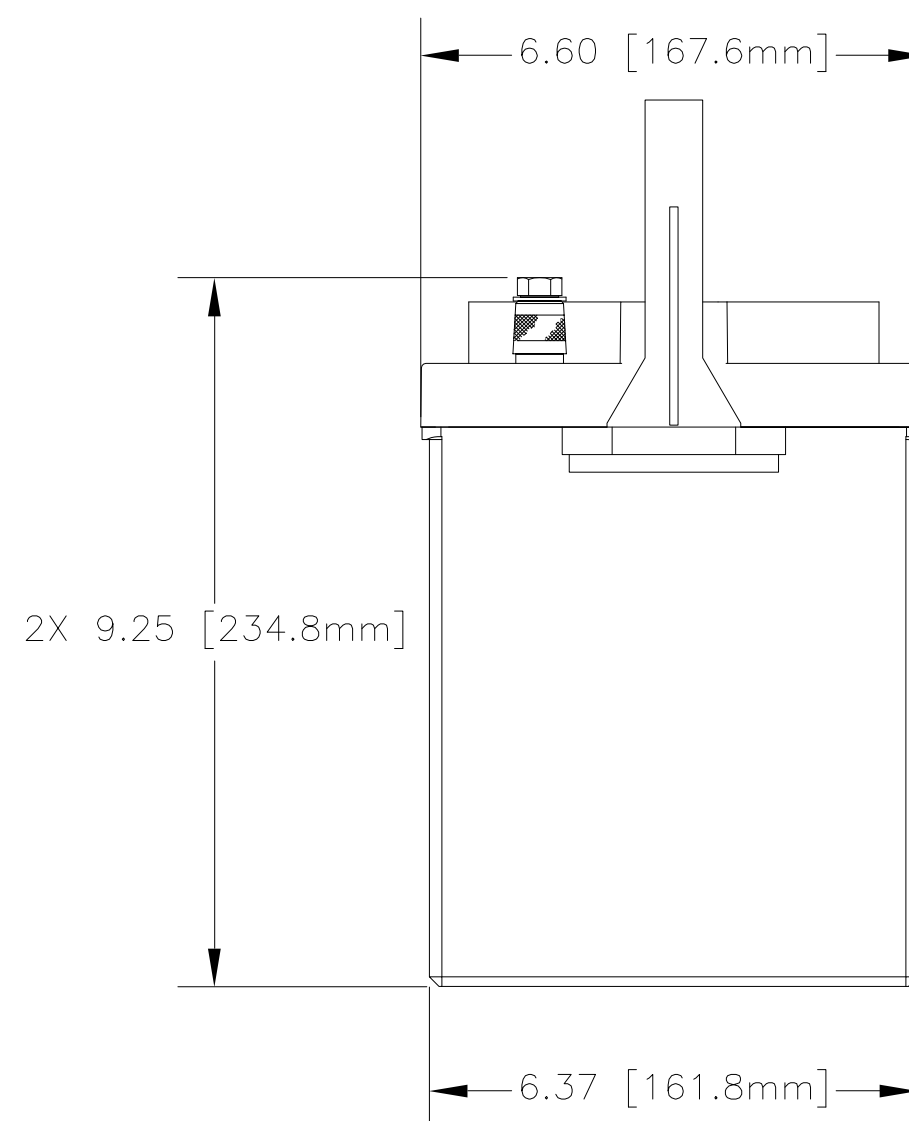
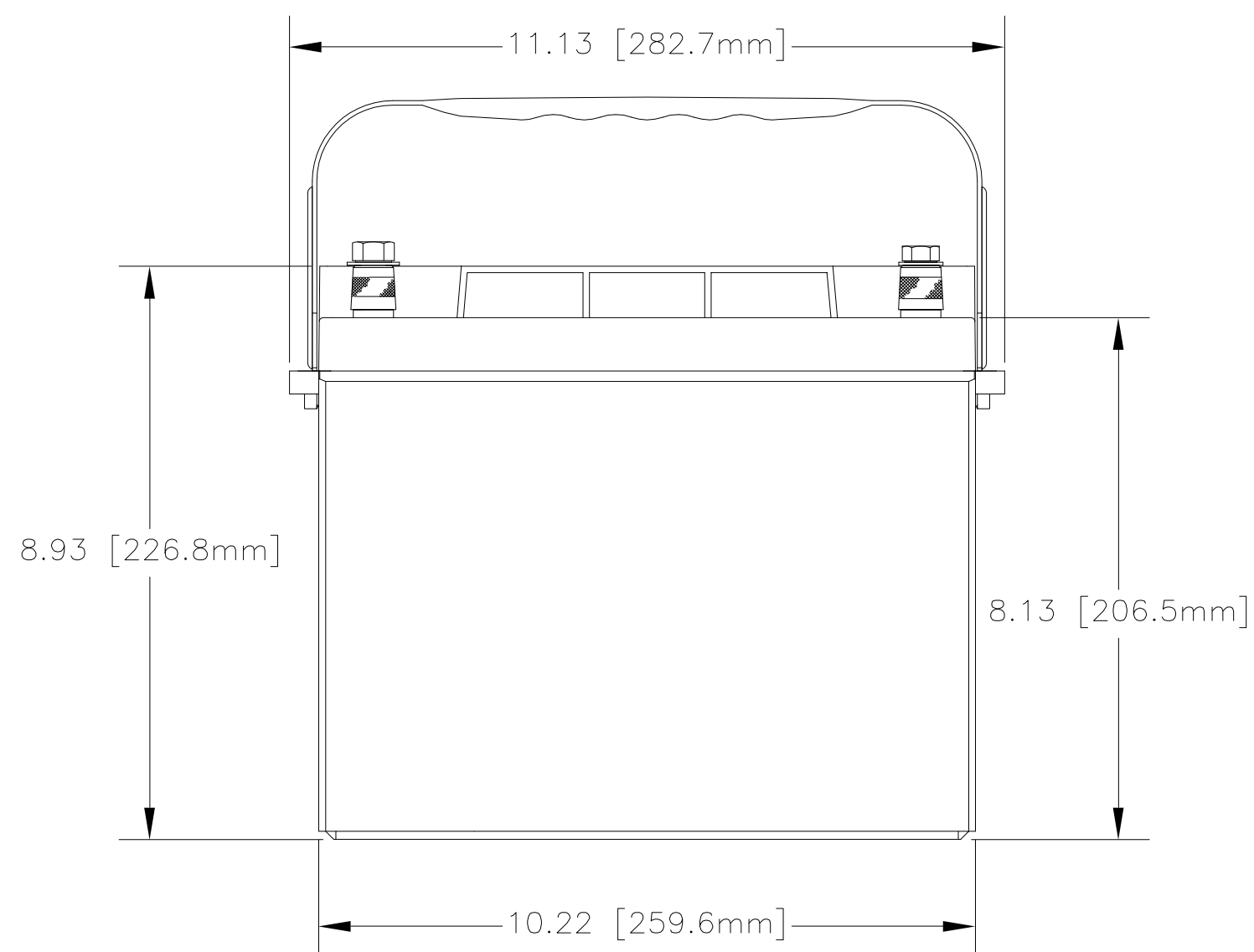

Solarlink Gmbh
 Drangstedter Str. 37
 D 27624 Bad Bederkesa
 GERMANY
 e-mail: info@solarlink.de
 web: www.solarlink.de

CAPACITY RATE	
PART NUMBER	GPL-24T
NOMINAL WEIGHT	56 LBS [25.5 KG]
AMPERE HOUR CAPACITY @ 20 HOUR 1.75 VOLTS/CELL @ 77°F (25°C)	80 AH
MINUTES OF DISCHARGE @ 25 AMPS 1.75 VOLTS/CELL @ 77°F (25°C)	149 MIN

ENVELOPE DRAWING

QTY REQD	CAGE CODE	PART OR IDENTIFYING NO.	NOMENCLATURE OR DESCRIPTION	MATERIAL SPECIFICATION	ITEM NO.
PARTS LIST					
UNLESS OTHERWISE SPECIFIED DIMENSIONS ARE IN INCHES TOLERANCES ARE: FRACTIONS DECIMALS ANGLES ± 1/32 .XX ± .06 ± 1° .XXX ± .060			CONTRACT NO.		CONCORDE BATTERY CORPORATION 2009 SAN BERNARDINO RD, W. COVINA, CA 91790
APPROVALS			DATE	TITLE	
DRAWN ELH			3/13/00	BATTERY, 12 VOLT, GPL-24T	
CHECKED S. VALDEZ			3/13/00	SIZE	REV
APPROVED JBT			3/16/00	CAGE CODE	A
ISSUED AT			5/23/02	DWG NO.	GPL-24T
SIMILAR TO NA	ACT WT NA	CALC WT NA	ISSUED AT	SCALE NONE	SHEET 1 OF 1

ENGINEERING COPY 23MAY02