

Ampair Pacific 100

Owners Manual Installation & Maintenance

INDEX	Page	FINAL ASSEMBLY	9
SAFETY:		OPERATION & PERFORMANCE	9
Read before assembling or using	1	Starting & Stopping	9
Assembly	1	Performance	9
Mounting	1	Smooth Running	9
Electrical	1/2	COMPONENT PARTS DRAWING	10
SYSTEM DESCRIPTION		MAINTENANCE & SPARES	
Introduction	2	Key to Component Parts Drawing	10/11
The Generator	2	DIMENSIONS	11
PACKING LIST:		Inspection	12
Pre-installation check	3	Major Disassembly	12
INSTALLATION		Pivot Section	12
Choice of Mounting Position	4	Electrical Section	13
Hawk 2 Land Based (House/Cabin)	4	Electrical Fault Finding Tips	13
Boat Based	5	Alternator Section	14
Stern Mount	5	Stator/Rotor replacement	14
Mounting Drawings	3-6	RECOMMENDED SPARES	14
Mizzen Bracket	6	WARRANTY	14
ELECTRICAL INSTALLATION		SERVICING & REPAIRS ADDRESS	14
Charge Control Regulator	7		
Regulator Wiring Diagrams	8		

AMPAIR PACIFIC 100 SAFETY

Read before assembling or using

Note. Do not assemble the generator, vane and turbine until the electrical installation is complete.

ASSEMBLY

Fit the tail vane first.

If you fit the wind turbine first, the machine will turn out of control & be a danger to approach.

MOUNTING

Very careful attention must be given to the strength and integrity of the mounting.

This should be capable of withstanding a peak horizontal load of 120kg (250lbs).

Note. The mounting pole should be vertical. The space between the blade tips and the mounting pole must be left clear. i.e. no clamps or other items should diminish this clearance. The pole base should have a rigid mounting. (The mounting should not rest on a resonant surface such as the centre of a cabin roof since this may transmit any vibration making the machine audible inside).

ELECTRICAL

It is important to fit a fuse. The fuse should be next to the battery terminal since, in the event of a fault or damage to the cable, the battery will supply the fault current.

CORRECT POLARITY

When wiring the system be aware that if the Pacific is connected to the wrong battery terminals, giving REVERSE POLARITY the output rectifiers may be destroyed or the internal soldered connections to the brush holders may melt.

Check and double-check polarity before final connection.

CABLE COLOURS

BROWN = (+) Positive. BLUE = (-) Negative.

CHARGE CONNECTION POINT

The Pacific Output must go straight to the batteries. If the Pacific is connected on the DOWNSTREAM (loads side) of the battery isolator switch, it leaves scope for damage to electrical equipment.

Under these conditions it is possible to run the Pacific whilst the battery is isolated. This can subject the system to excess voltage. Take care when disconnecting the Generator in a high wind as the terminal voltage is enough to give a mild electric shock.

When mounting the Pacific on its pole or bracket. the cable needs to be fed down through the mounting. When arranging this cable make sure it cannot chafe at the point where it leaves the mounting pole. Either lead the cable out of the bottom of the pole in a gentle curve or drill an exit hole in the pole large enough to take a rubber grommet to protect the cable from the sharp edges of the hole.

REGULATION

It is advisable to fit a Charge Control Regulator if the Generator is regularly left to charge batteries where no loads are present. Under these conditions over-charge will slowly drive off the battery electrolyte which, if not topped up, will eventually damage the batteries.

HANDLING

Stopping. The wind turbine has been designed to survive storms, however, it is a good plan to stop the machine if a hurricane is expected or to carry out inspection. To do this, proceed with caution, approach the Pacific from downwind and grasp the tail vane (use a boathook for marine generators).

Carefully turn the machine off wind and, when the blades stop, throw a rope over them and tie down.

Never throw a rope into the turning blades.

To avoid personal injury wear sturdy gloves as a precaution. The wind turbine blades are capable of causing GRAVE PERSONAL INJURY and should be treated with the same respect as an aircraft propeller.

CHECK

Check all fixings at regular intervals, especially after severe winds.

SYSTEM DESCRIPTION

INTRODUCTION

The Ampair Pacific 100 is a wind driven generator. capable of supplying up to 100 Watts of electrical power at either 12 or 24 volts for charging batteries.

THE GENERATOR

The unit consists of a two part cast aluminium body, the two parts sealed by an "O" ring. Two six pole permanent magnet rotors run, with their poles in line, on a stainless steel shaft. The shaft runs in two sealed. grease-packed ball bearings with the front bearing protected by a shaft seal. Two six-pole stators are arranged with their poles staggered at 30 degrees to minimise "cogging" or break-out torque and so allow easy starting.

The unit is assembled with one stator in the main body casting and the other in the nose piece.

During assembly these are precisely aligned on the test bench to give optimum performance.

A small timing mark is made at the junction of the case

halves to allow accurate re-assembly.

The alternating current output of the stators is rectified by two bridge rectifiers, one per stator.

The DC output of the two rectifiers is paralleled and passes to two carbon brushes mounted in brush holders located on the sides of the lower body section.

The carbon brushes carry the output to two phosphor-bronze slip rings mounted on the stationary pivot shaft, allowing the machine to rotate to follow the wind.

To absorb any electrical noise arising from the slip-rings and brushes, a metal oxide varistor is wired across the output between rectifiers and brushes.

The output is electrically isolated from the case.

The body is mounted on the pivot shaft where it runs on a sealed grease packed ball bearing at the top and a composite plain bearing at the base. The top bearing is captive in the body, the lower bearing is located in the body by a stainless steel spiral retaining ring.

The pivot section contains an "O" ring seal on each brush holder cap, an "O" ring around the lower bearing to body junction and a "V" seal where the pivot shaft passes through the lower bearing.

The pivot axis passes through the centre of gravity of the assembled machine. This is necessary to ensure alignment into the wind in light breezes without undue spinning.

The wind turbine consists of six cambered and twisted compression moulded blades of glass-fibre reinforced polypropylene. This material has exceptional fatigue resistance and retains its durability down to sub-zero temperatures.

The blades are factory selected for balance to less than one gramme and are delivered as colour coded matched pairs, they are clamped between a cast aluminium nose cone and an aluminium alloy backplate using M8 x 45 stainless steel fasteners with shakeproof washers and nuts, (two of each per blade).

The hub is fitted to the generator shaft taper where a dowel pin is located to prevent relative rotation and retained by an M10 plain washer and nyloc nut with a **left-handed thread**.

An aluminium alloy tail vane is clamped to the rear of the generator body using three M8 x 25 stainless steel screws, six plain washers and three lock nuts. The vane of marine generators is provided with a grab hole at its lower corner to facilitate turning the unit cross-wind to stop the wind turbine rotating when required.

PACKING LIST – Pre-Installation Check

AMPAIR PACIFIC 100 GENERATOR

Check that a complete and undamaged set of parts has been received.

Have you received the voltage ordered 12V or 24V?

Carton Contains :-

Generator, complete with assembled hub and pivot.
Pacific Manual
Six Wind Turbine Blades, three colour coded pairs (see coloured code on base of blade).
Direction vane.
Hardware kit.

Wind Vane Fixings Blade Fixings

3 M8 x 25 set screws	12 M8 x 45 fasteners
6 M8 plain washers	12 M8 shakeproof washers
3 M8 nyloc nuts	12 M8 nuts

PACIFIC STERN MOUNT KIT (P1031)

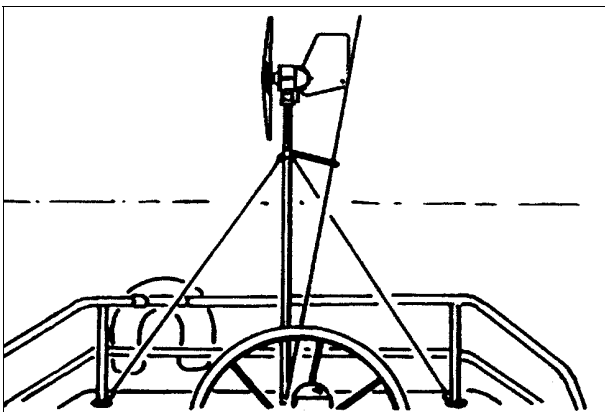

This arrangement places the blade tips 2 metres (7 feet) above the base fixing. If there is a raised area adjacent upon which people may stand, raise this base accordingly.

Carton contains :-

Top Pole, 1200mm, 2 x 8.5mm holes one end, 1x 8.5mm hole at other end, + 2 x 10.5mm holes.
Bottom Pole, 1200mm, 2 x 8.5mm holes one end, 2 x 8.5mm at other end.
Strut Pole, 970mm, 25mm OD.
Stay wires: two, terminated by thimbles and "D" ring nuts.

Hardware kit: containing, yoke, two angle feet, backstay clamp shell, anodised aluminium alloy tube joiner.

Strut, yoke, joiner tube & feet fixings:

1 M6 x 40 set screw	1 M8 x 70 hex bolt
2 M6 x 35 hex screw	2 M8 plain washers
3 M6 shakeproof washers	1 M8 Nyloc nut
3 M6 Nyloc nuts	2 M8 x 60 hex bolts
1 M10 threaded rod 85mm	2 M8 shakeproof washers
2 M10 shakeproof washers	2 M8 hex nuts

MIZZEN BRACKET (P1032)

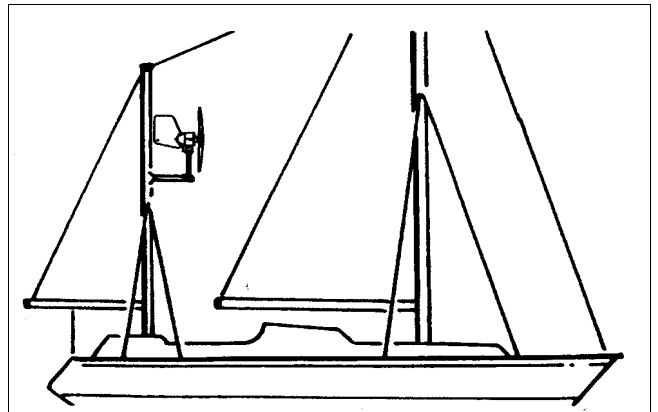

Carton contains :-

The Bracket
2 M10 x 150mm threaded rod,
8 M10 nuts,
8 M10 plain washers,
4 M10 shakeproof washers

GANTRY MOUNT (P1030)

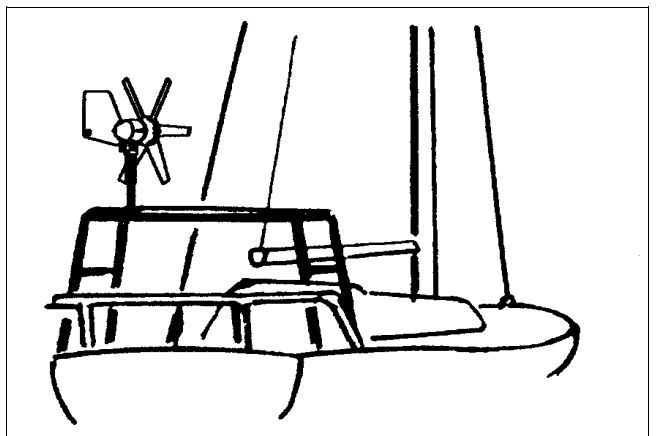

Carton contains :-

Pole with base flange (800mm x48mm outside diameter)

INSTALLATION

CHOICE OF MOUNTING POSITION (Land based siting and installation)

The Wind Generator should be sited as high as practicable, clear of windbreaks or buildings and away from sources of turbulence. These conditions are shown diagrammatically below.

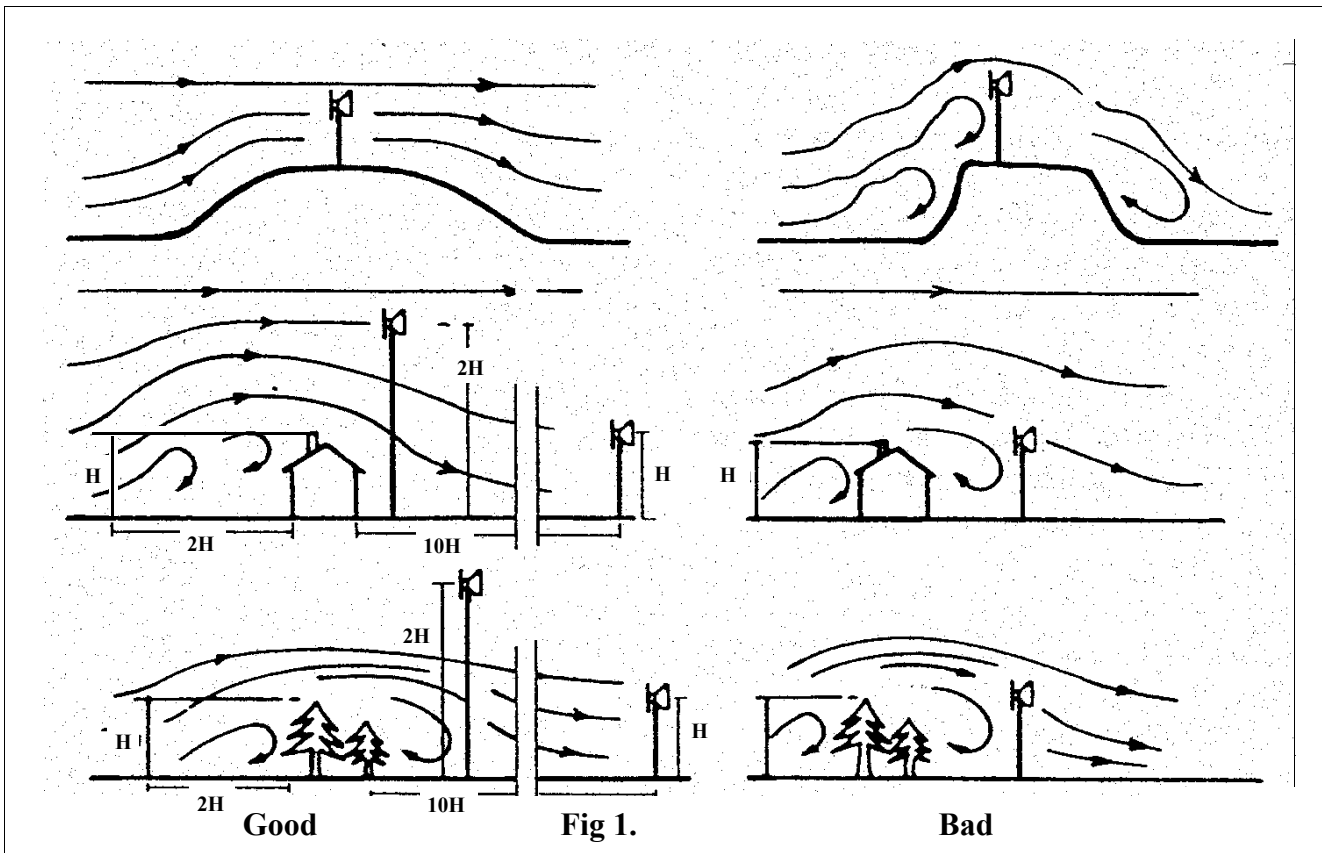

Warning:

Before a Wind Generator is installed in an excessively windy location, the operators must satisfy themselves that the site is suitable. It may be necessary to log site wind speed and direction data at various heights prior to installing the machine.

Any indication of turbulence means that the Generator should be re-sited or raised above the turbulence. Wind Data must be local and not from close-by. Avoid roof top mounting which can give rise to turbulence, shock loads and vibration.

Installation (Mechanical)

Free-standing installations should generally conform to Fig. 1. The main components are:

Mast: of steel tube (water pipe or scaffold tube), alloy tube or wood (telegraph pole)

If the guys are unsuitable (grazing cattle) then use a telegraph pole one third buried or a lattice tower as an expensive alternative.

Guy: Usually galvanised steel wire protected by plastic sheath and fitted with end thimbles.

Do not use a material that will stretch or deteriorate. Three equally spaced guys (120°) will assist raising and lowering the assembled mast. A high mast will require

intermediary guying. The top guys hold the mast upright, the lower prevent it from buckling.

The top fixing point should allow for minimum overhang of the Generator i.e. be only a short distance below the wind turbine blade tips.

Tensioners: The simple and easiest method of tensioning guys, but adjustment must be uniform, since it is the guys that resist the thrust of the wind turbine.

Base: This is to carry the weight of the Generator and Mast only. Fixing again depends on the ground state but metal pegs driven into soil are often sufficient. A lattice tower would need a concrete base with rawlbolt fixings. It is often convenient to make a pivot arrangement for the base in-line with one guy anchor to aid raising and lowering.

Ground anchors:

These should be suitable eyebolts fixed in the ground and in line with the guys. Anchors in soft earth may require concrete, gravel or clay soils require "auger" type anchors and rocky ground may need drilling and expanding rock anchors. Only

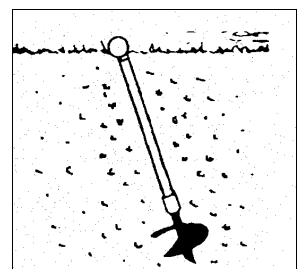

the eye should be visible above ground.
 Avoid waterlogged soils which have poor holding and anchor below the frost level.

Low Temperature Operation: Plastic materials do not perform well in extreme cold, becoming brittle and breaking. This applies to wind turbine blades, whether glass filled or not. Operation at around 0°C should not be a problem, but most materials are vulnerable at -20°C and cannot be warranted to survive indefinitely.

Pacific's glass filled polypropylene blades, moulded with large sized fibres in a compression process, are superior to nylon, carbon polymer or other plastics in this respect. However, when ice factors are also considered, the prediction of blade reliability is even more difficult. Other materials are also suspect. Examples are Nitrile used in exposed seals and "O" rings and basic PVC cable sheathing.

For this reason Pacific uses Neoprene and Viton™ components where possible and "Arctic" grade PVC Grease used in sealed bearings allows performance to (minus) -30°C or below, but component tolerances (ball and ring) can lead to greater friction and increased wear causing reduced bearing life.

Lightning: Directly earth all metalwork. Bury output cables (½m depth) between mast and battery position for better protection than suspending in air. Either run cabling through plastic conduit or use a type specified for burying.

CHOICE OF MOUNTING: (Boat based)

- a) On an extended, stayed pole on the stern of a boat. see Figure. 9
- b) On a bracket on the Mizzen of a yacht, see Figure 3
- c) At the main or mizzen masthead of a yacht.
- d) On a custom made welded pushpit structure, "A" frame, gantry etc.

PACIFIC STERN MOUNT (for Marine use)

Very careful attention must be given to the strength and integrity of the mounting. This should be capable of withstanding a peak horizontal load of 120kg (250lbs). Note. The mounting pole should be vertical. The space between the blade tips and the mounting pole must be left clear, i.e. no clamps or other items should diminish this clearance. The pole base should be mounted where the structure is very rigid. The mounting should not rest on a resonant surface such as the centre of a cabin roof since this may transmit any vibration making the machine audible inside.

- a) **Check.** Ensure that a complete and undamaged set of parts has been received.
- b) **Pole position.** The pole base fixing may be moved to one side provided that, when viewed from above, the angle between the strut and either wire is greater than 45 degrees.

- c) **Pole assembly.** Using the joiner tube and M6 x 12

screws and shakeproof washers, assemble the poles . A thread locking solution (e.g. Loctite 222) will stop screws shaking loose due to long term vibration. It may be easier to feed the cable through the poles as they are assembled.

- d) **Feet.** Using the M8 x 65 bolt, washers and nut, fix the feet to the pole end and screw down the feet. The feet should be arranged so the pole can pivot in line with the strut. This usually means aligned fore and aft unless the pole is off-centre.

- e) **Stay Wires.** Having assembled the poles with joiner tubes, site the pole and attach the two stay wires with the yoke in place on the pole. Find suitable points for the stay wire base fixings, allowing for the fact that these will be under considerable tension in use. "Bottle screws" are suggested as a tensioning method.

Figure 9. Stern Mount Kit

- f) **Backstay strut.** File the groove in the strut pole end and clamp shell to accommodate the backstay wire diameter less 0.5mm. Cut the strut pole to length required. Drill the hole for the strut to yoke bolt in situ to ensure correct orientation of holes.

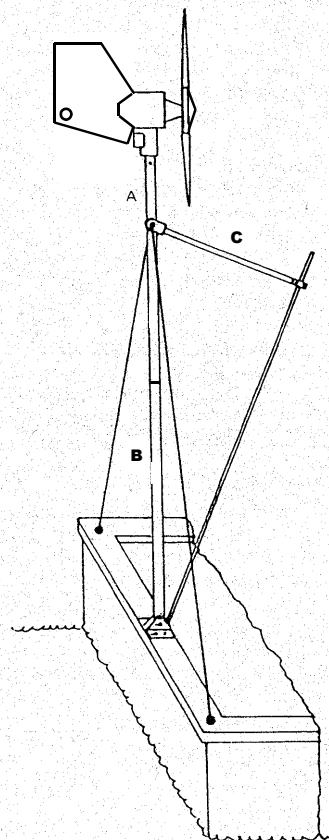
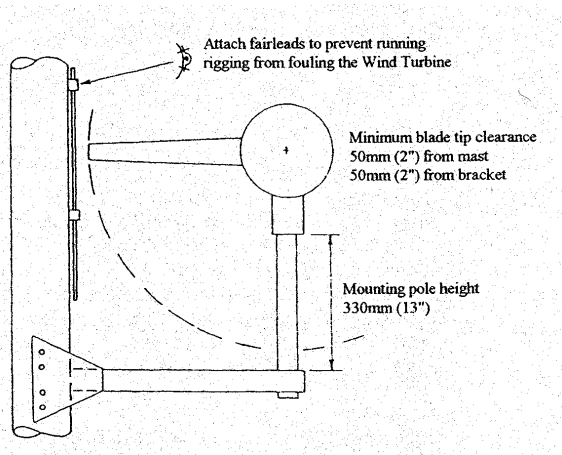

Figure 2. Stern Mount Kit



MIZZEN MOUNTING
Figure 3 Mizzen Bracket

The major load that the bracket has to withstand is one of torsion, hence the box section. At 100mm wide this is close to the width of many mizzen masts and any slight difference can be accommodated by bending the end plates to suit or by spacing with nuts and washers.

Drill through the end plates and mizzen and fit using the M10 fixings provided. Monel rivets are a possible alternative to the bolted method above.
Note. Do not assemble the generator, vane and turbine until the electrical installation is prepared

ELECTRICAL INSTALLATION

When mounting the Pacific on its pole or bracket, the cable needs to be fed down through the mounting. When arranging this cable make sure it cannot chafe at the point where it leaves the mounting pole. Either lead the cable out of the bottom of the pole in a gentle curve or, drill an exit hole in the pole large enough to take a rubber grommet to protect the cable from the sharp edges of the hole.

a) Cables: Having sited the Pacific mounting, measure the cable run distance to the batteries. If this distance is less than 10 metres (20 metres 24V systems) use 1.5sq. mm (16 AWG cable, if less than 20 metres (40 metres 24V systems), use 2.5sq. mm (14 AWG) cable. Use a similar type of cable to that on the Pacific. Always use tinned stranded conductors for best corrosion protection on boats.

b) Connectors: To carry power from the Pacific to internal wiring we recommend that a quality water-tight connector be fitted

next to the battery.

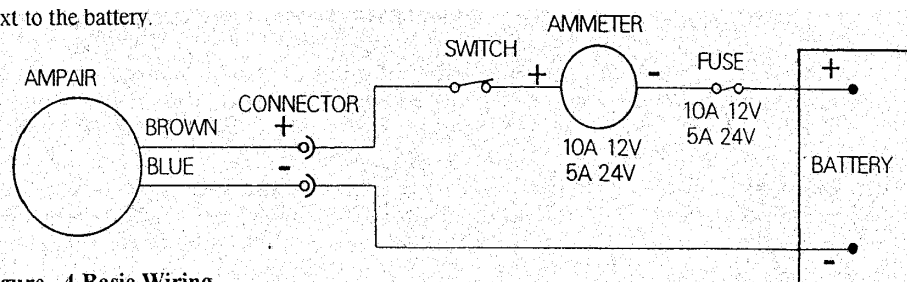

Figure. 4 Basic Wiring.

e) Installation: Wiring between the generator (or junction box, connector etc.) and the battery area should be clipped at regular intervals to the structure for safety and a neat job.

d) Protecting the System: The simplest possible arrangement feeds the power from the Pacific directly to the battery via an in-line fuse rated at 10 Amps (5 Amps 24V System) in the positive line next to the battery.

e) Wiring Options: in Fig 4. two optional components have been added to show where they might be wired in the circuit. The switch, which may be used as a simple means of charge control, should be rated at 15 Amps DC to ensure long life.

The Ammeter is wired in series (assuming it to be of the internal shunt variety) with one line. This will allow the machine output to be seen at all times. As shown, the positive (+) connection of the ammeter is made to the generator, whilst the negative (-) is made to the battery.
Never connect an ammeter across the supply.

CAUTION. It is most important to fit a fuse. The fuse should be next to the battery terminal since, in the event of a fault or damage to the cable, the battery will supply the fault-current.

CORRECT POLARITY. When wiring the system be aware that if the Pacific is connected to the wrong battery terminals, giving REVERSE POLARITY the output rectifiers may be destroyed or the internal soldered connections to the brush holders may melt. Check and double-check polarity before final connection.

CABLE COLOURS:-

Brown = (+) Positive : Blue = (-) Negative

CHARGE CONNECTION POINT

The Pacific output must go straight to the batteries. If the Pacific is connected on the DOWNSTREAM (loads side) of the battery isolator switch, it leaves scope for damage to electrical equipment. Under these conditions it is possible to run the Pacific whilst the battery is isolated. This can subject the system to excess voltage.

REGULATORS

AMPAIR manufacture 3 Charge Control Regulators to protect lead acid batteries from overcharge.

These are not "shunt" type regulators, which dissipate excess charge as heat, but an electronic power switch which disconnects the generator from the battery at the regulation voltage.

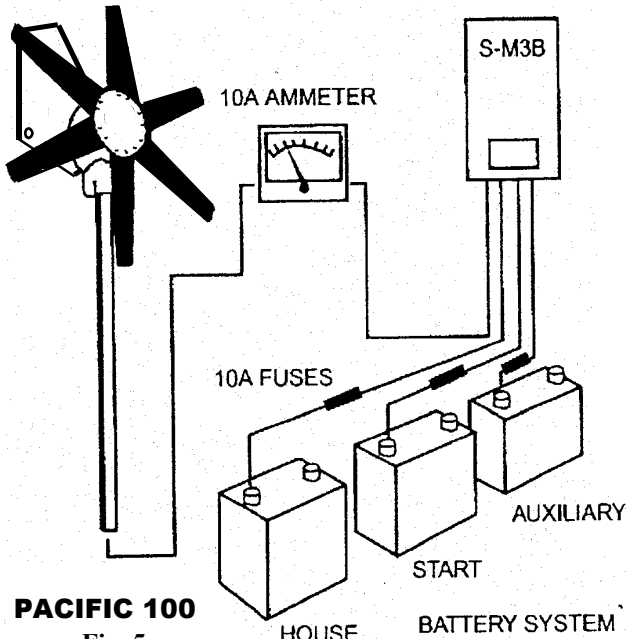

12V System showing 3 batteries

installed with an Ampair S-M3B Charge Control Regulator

Regulators S-M1B & S-M3B have a single 100 watt input (Pacific, Aquair or Solar) and 2 level sensing. The lower voltage (Lo) connection regulates at 0.4 Volts below the high (Hi) connection for 12V systems (0.8V for 24V systems). "Hi" connection is appropriate for liquid electrolyte batteries and/or live aboard situations, 'Lo' connection for gel batteries and/or infrequent use.

The battery voltage is sensed at the regulator output connection, therefore install the regulator as near the battery as practicable and keep the connecting cables short.

Regulator type S-M1B has one output battery connection. Regulator S-M3B has three output connections to serve up to three battery banks.

The third Regulator D-M1B has two 100Watt inputs, (any two from Pacific, Aquair or Solar), supplying a single battery bank at a fixed regulation voltage.

All regulators feature the same multi-stage regulation programme which has regulation voltages of
Lo = 13.6V, Hi = 14.0V for 12V systems
Lo = 27.2V, Hi = 28.0V for 24V systems.

MODEL (12V)	S-MOB	S-M3B	D-M1B
Source	1	1	2
Source Power W	100	100	2 x 100
Programme	M	M	M
Battery Banks	1	3	1
Setpoint V (low)	13.6	13.6	-
Setpoint V (high)	14.0	14.0	14.0
Equalisation V+	0.4	0.4	0.4

MODEL (24)	S-M1B	S-M3B	D-M1B
Source	1	1	2
Source Power W	100	100	2 x 100
Programme	M	M	M
Battery Banks	1	3	1
Setpoint V (low)	27.2	27.2	-
Setpoint V (high)	28.0	28.0	28.0
Equalisation V+	0.8	0.8	0.8

Charging is continuous until the Lo or Hi voltage is reached, depending on the battery output used.

The generator is now disconnected from the battery. Off-charge, the battery voltage will fall.

At a voltage of 0.5V below the regulation voltage a 30-second time delay is activated. This delay prevents the regulator from oscillation (hunting) when charging batteries under load. After 30 seconds has elapsed, the generator/battery connection is remade and charging continues to the regulation cut-out voltage..

A cycle counter counts the charge/disconnect cycles and at the tenth cycle increases the regulation voltage for one cycle only by 0.4 volt to Lo = 14.0V or Hi = 14.4V for 12V systems (0.8V for 24V systems Lo = 28.0V, Hi = 28.8V). This provides an equalisation charge for the battery. Subsequent cycles return to the lower settings until a further 9 cycles are completed.

Ammeter:

We recommend fitting an ammeter to monitor charging. Fuses: Battery protection fuses should be fitted. Use 10Amp values in 12 volt systems, 5Amp for 24volts.

WIRING: Use suitably insulated cable of 1.5 sq. mm (16 AWG) between regulator and battery, for single source systems, 2.5 sq. mm (14 AWG.) for dual source. For wiring to the regulator see appropriate generator wiring section. The use of Screened Cables is recommended if the cables run close to equipment radiating strong electrical fields e.g. Radio transmitters or Aerials

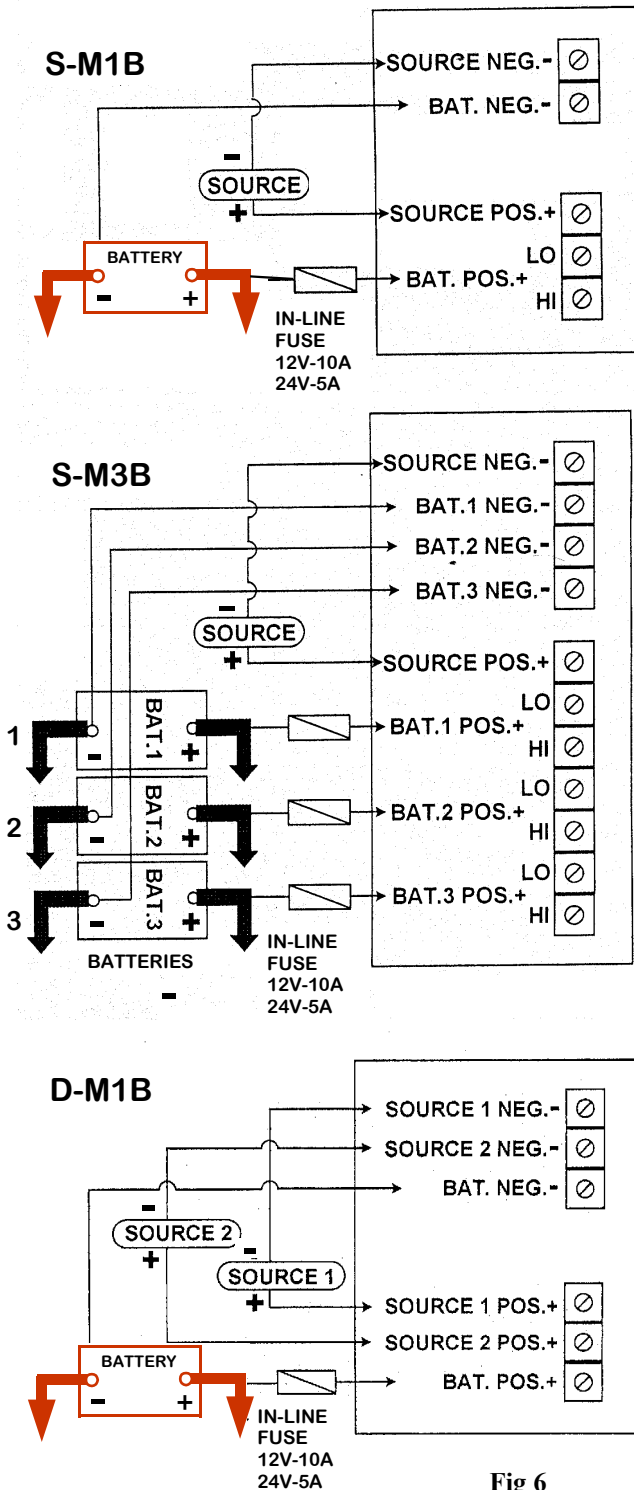

Fig 6

INSTALLATION

At initial start-up, allow a gap of 1 min. for circuit timing functions to become active.

CHARGE CONTROL Protecting the system

Fuse Warning - Never omit fuses, simple in-line fuse carriers may be used, they protect your system from excessive battery currents in the event of a serious electrical fault. **If they keep blowing, find out why.**

Fuses = 10A - 12V systems : 5A - 24V systems.

All multistage regulators are internally protected by an SAE cartridge fuse. These are not substitutes for battery protection fuses. The fuses must be next to the battery terminals since, in the event of a fault, the batteries would source the fault current. Check and double-check polarities before making connections, insert the fuses in the fuse carriers last of all.

Corrosion: This is the enemy of all electrical connections, especially in marine environments. Site regulators in a weather proof location, as dry as possible and splash proof. Inspect all terminations and connections for signs of corrosion. Rectify by cleaning, remaking etc. Use tinned copper wire for extension leads to prevent corrosion spreading inside cable insulation.

Operating Problems: A digital multimeter is useful for checking operation/fault finding if no permanent monitoring instruments are used.

Battery voltage levels and those of the charging source can be read directly. Charging current readings will require the multimeter to be installed in line. In this way currents into and out of the regulator can be observed. Do not remove battery connections since regulator operation depends on a very small supply current.

If the regulator is suspect then it can be temporarily bypassed by connecting the source positive direct to a battery positive. The negative connections are common and do not need disturbing unless regulator replacement is necessary.

Use the multimeter continuity range to confirm all cable runs are low resistance.

Operation: When installed, the generator and regulator will run and maintain the batteries automatically. The unit may be run in conjunction with any other charge-source with no known interactive problems. Regular battery inspection and topping up must still be carried out to obtain maximum battery life.

FAULTY REGULATOR

Stop the wind turbine from turning & tie off before disconnecting any cables. Do not remove battery connections when generator is supplying charge current, as this can destroy the regulator!

If the regulator is suspect, then it can be temporarily bypassed, i.e. connect the Pacific directly to the battery terminals observing correct polarity. If this reinstates correct charging, then the regulator must be serviced or replaced.

Regulators draw a small current (typically 1mA at 12V) from the battery to activate the sense and control circuits.

Without this connection the regulator will be inoperative

FINAL ASSEMBLY

a) Mounting the Pacific: Put a thin film of grease on the pivot shaft and its fixing screw threads to prevent corrosion. Bring the Pacific body to the mounting arrangement, pass the 2 core cable down the mounting pole, insert the pivot shaft of the Pacific into the top and secure the fasteners.

The top of the pole is made to compress the lower pivot bearing "V" seal by about 2mm, if you have made your own fixing tube, be aware of this point to ensure free turning and weather proof sealing.

b) Output Cable: Make the final electrical connections to the battery, as shown in the electrical section, Insert the fuse or fuses in their carriers.

CAUTION: Fit the tail vane first.

If you fit the wind turbine first, the machine will turn out of control and be a danger to approach.

c) Tail Vane: Clamp the tail vane using the M8 x 25 screws washers and lock nuts.

d) Wind turbine: Assemble the blades to the hub with the concave or hollow side facing the wind. Using the M8 x 45 square shoulder fasteners, shakeproof washers and nuts, fix the blades in place observing the colour-coded pairs. These must go opposite each other.

FAILURE TO OBSERVE THIS POINT CAN CAUSE THE MACHINE TO RUN OUT OF BALANCE.

The holes in the blades are deliberately a tight fit and it may be necessary to turn the fasteners as they are inserted. First, evenly tighten all the nuts by hand, then, fully tighten opposite pairs with a spanner. Finally, recheck the tightness of all the nuts.

Note. Put a rope over the Pacific passing through the blades to prevent its turning as you carry out the final checks.

Once the mounting is complete, make sure all personnel are clear, turn the Pacific to face the wind and whilst holding the vane step back and remove the rope.

Check all fixings at regular intervals, especially after severe winds.

OPERATION & PERFORMANCE

STARTING AND STOPPING

a) Starting up. It is assumed that the Pacific has been assembled and installed in accordance with the INSTALLATION Section.

b) Stopping. The wind turbine has been designed to survive storms, however, it is a good plan to stop the machine if a hurricane is expected or to carry out inspection. To do this, proceed with caution, approach the Pacific from downwind and grasp the tail vane (use a boathook for marine generators). Carefully turn the

machine off wind and, when the blades stop, throw a rope over them and tie down.

Never throw a rope into the turning blades.

CAUTION

To avoid personal injury wear sturdy gloves as a precaution. The wind turbine blades are capable of causing GRAVE PERSONAL INJURY and should be treated with the same respect as an aircraft propeller.

PERFORMANCE

The graph shows the output for a range of wind speeds. The drag due to the wind turbine is about 22kg (50lbs) at 50 knots wind speed.

SMOOTH RUNNING

The design of the blades makes the Pacific a very quiet running machine. If vibration is encountered, this is evidence that the turbine is running out of balance. To prevent any resultant noise and the risk of fixings working loose, it is most important to take action. Remove the turbine, take out the blades and examine them to check that the pairs are placed opposite.

If they are correctly assembled, contact Ampair .

To confirm correct blade performance, firstly weigh the blades, the pairs should be the same weight, within one

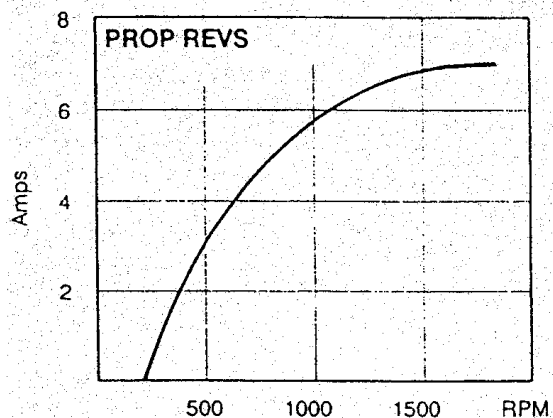
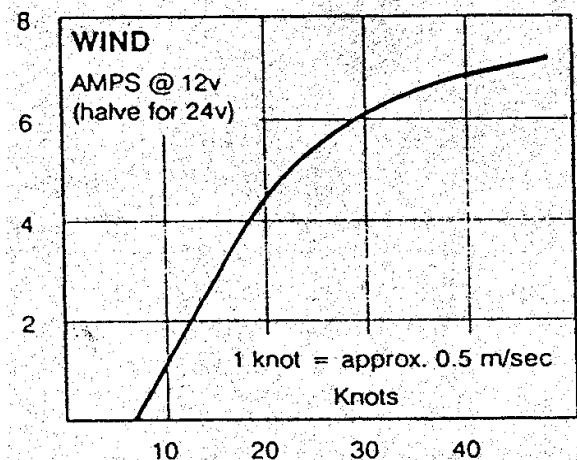

Fig 7

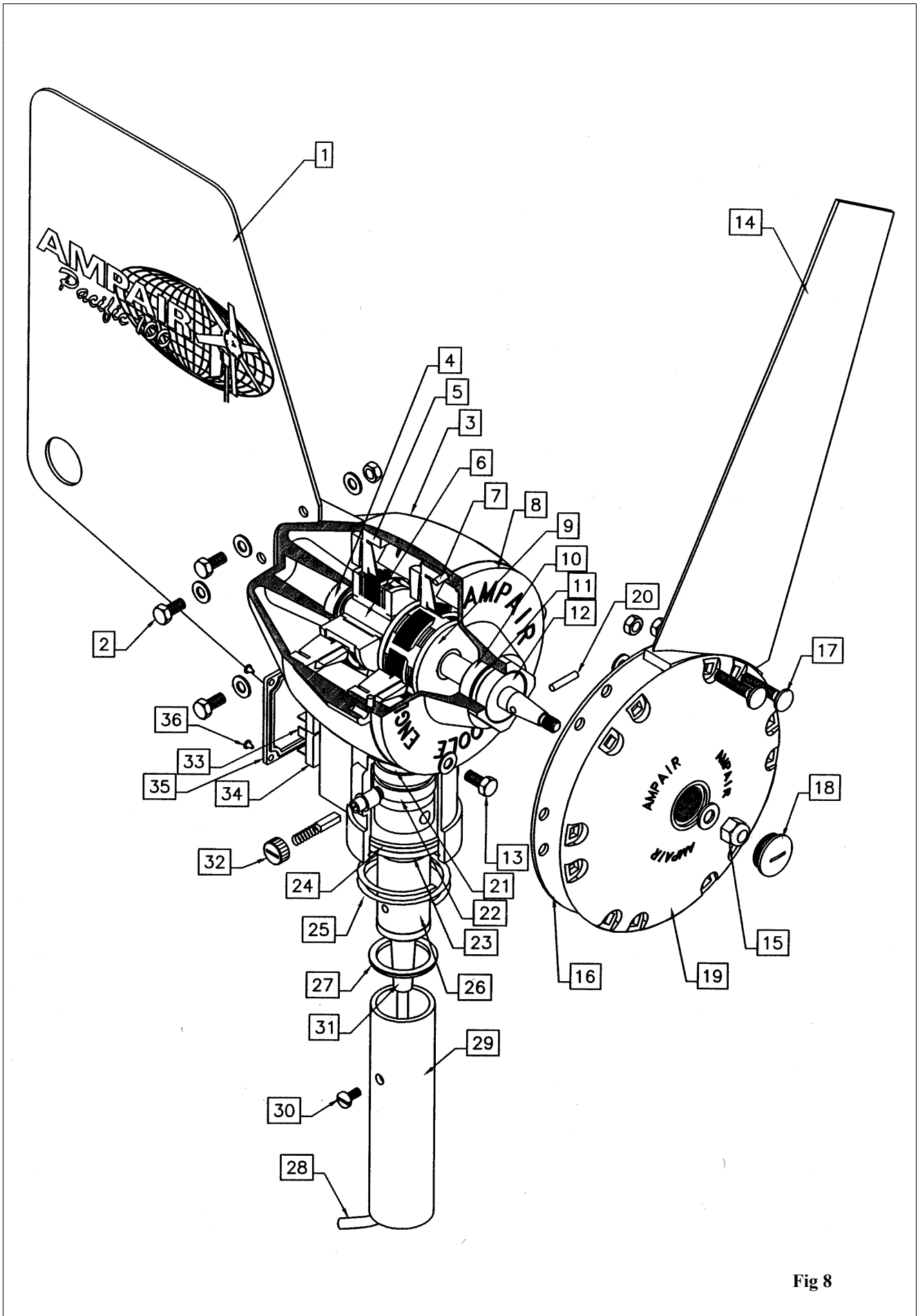
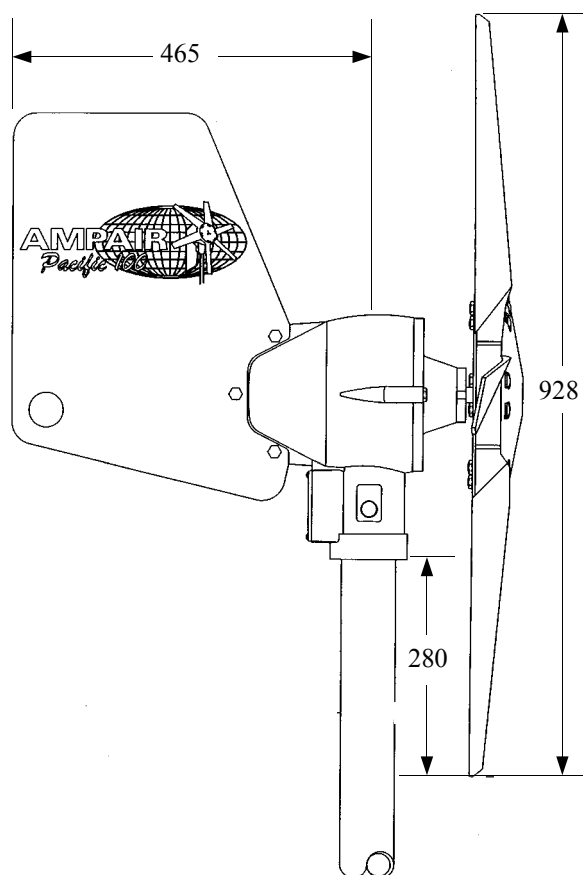

Fig 8

PACIFIC 100 COMPONENT PARTS

KEY TO CUTAWAY DRAWING

1. Tail vane
2. M8 x 25 screw, plain washer x 2, & nyloc nut (3 of each)
3. After-body
4. Rear ball bearing: Type 6202. 15 x 35 x 11mm with frictionless cover
5. Six pole stator (2 off)
6. Shaft
7. "O" ring seal: international size 358
8. Fore-body
9. Six pole permanent magnet rotor (2 off)
10. Front ball bearing: Type 6203. 17 x 40 x 12mm with frictionless cover
11. Internal circlip: 40 x 1.75mm
12. Shaft seal: 17 x 40 x 7mm rubber coated, plain lip
13. M8 x 25mm set screw, fibre washer, plain washer & shakeproof washer (2 of each)
14. Wind turbine blade (6 off, available as balanced pairs)
15. Nut Nyloc M10 left handed thread & plain washer
16. Back plate
17. M8 x 45mm square shoulder fasteners, c/w shakeproof washer & nut (12 off)
18. Sealing cap
19. Nose Cone
20. Dowel for locating hub centre
21. Ball bearing: Type 6202 15 x 35 x 11mm
22. Slip-ring assembly
23. Lower bearing
24. "O" ring seal: international size 332
25. Spiral retaining ring
26. Pivot
27. "V" seal (neoprene)
28. Output cable: tinned, stranded copper flex, twin 1.5sq. mm arctic grade PVC sheath, three metres length
29. Mounting pole
30. Socket Cap Screw M8 x 16 & shakeproof washer
31. Cable gland with flexible tail
32. Brush cap, brush, "O" ring seal (international size 012 neoprene), brush holder & spring connector (2 of each)
33. Suppressor: metal oxide varistor
34. Rectifier c/w M5 x 16mm screw (2 of each)
35. Rear cover plate
36. Self-tapping screw, Number 8 x 3/8" U K designation (4 off)



DIMENSIONS.

Pacific Body.

Shaft diameter	17mm
Pivot shaft diameter	40mm
Body height (from machine base)	266mm
Body diameter	175mm
Body length (including shaft)	316mm
Body length (with lid)	263mm
Generator body and pivot weight	9kg

Assembled Pacific Wind Generator.

Wind turbine diameter	928mm
Tip of blades below top of pole	280mm
Mounting pole inside diameter	40mm
Mounting pole outside diameter	48mm
Turning radius	480mm
Weight	12.6 Kg

Electrical.

Output nominal voltage	12V or 24V
Peak output power	100W
The output is fully rectified and isolated from the case.	

gram. Secondly, lay the assembled turbine on a flat surface face down, this will reveal any blade bend as the tips should be above the surface by an equal amount plus or minus 3 mm.

Blades will be checked and re-balanced, free of charge, on request, if returned to the factory.

Any other machine noise should also be investigated.

Only after very extended running life should there be any detectable bearing noise.

If this is the case, refer to the maintenance section for instructions on their replacement.

INSPECTION

First. stop the machine, see section on stopping.

Caution: To avoid personal injury wear sturdy gloves as a precaution.

The wind turbine blades are capable of causing GRAVE PERSONAL INJURY and should be treated with the same respect as an aircraft propeller.

Regularly inspect the following :

Hub to shaft nut (priority No. 1)

Blade fasteners & nuts

Wind turbine blades

Tail vane screws

Pole mount screws

Brushes

The Pacific Wind Generator should be inspected regularly, particularly after stormy weather, for signs of accidental damage. Any minor nicks in the edge of a blade may be dressed out but the blade must be replaced if there is any sign of damage or cracking near the root.

Since the blades are supplied as matched, balanced pairs, any damaged blade must be replaced along with its opposite number.

The unit may be run with two blades missing, whilst the replacements are obtained, at reduced performance since difficulty in starting will be encountered.

NEVER ALLOW THE MACHINE TO RUN OUT OF BALANCE

The blade material has exceptional fatigue resistance which is of the utmost importance in hostile locations such as tropical sunshine and mountain tops.

The material is, however, subject to slow degradation due to ultra violet light which increases towards the tropics and with altitude.

This process is slow and when it becomes apparent as a white powdering of the blade surface, particularly along leading and trailing edges, the blades may be carefully painted with two-pack polyurethane after light sanding.

Do not mix up the balanced pairs.

The shaft seal protecting the front bearing should be renewed after 2 - 3 years of regular use.

Also the lower bearing and "O" seal. The ball bearings should be replaced when they become noisy, causing a once per revolution 'knock'.

Regularly check the security of the fixings on hub, vane and pole. If damage to the paint occurs, clean off any corrosion and repaint. Clean the brushes, taking care not to damage the brush spring when handling.

MAJOR DISASSEMBLY

a) Stop the Pacific, see Section on Stopping.

b) Disconnect from the batteries, removing the fuses first, see Figures 5 & 6 (Circuit diagrams).

c) Remove the wind turbine. The centre nut has a left handed thread and so is rotated clockwise to remove. Pull the hub away from the machine and give a very careful tap on the end of the shaft with a rubber faced mallet if necessary. If difficulty is encountered in removing the hub from the shaft, avoid hammering on the shaft-end. Ampair offer a purpose made puller.

d) Remove the tail vane.

e) Feed some excess cable length up the pole.

f) Remove the fastener from the pivot and lift the machine off the pole.

PIVOT SECTION

With the machine on the bench, undo the two black brush holder caps and remove the brushes to a safe place.

Prise out the end of the spiral retaining ring from around the pivot lower bearing. Withdraw the pivot assembly, a good tug may be needed. Inspect the slip rings, clean if necessary.

Inspect the lower bearing, if this is loose, obtain a replacement. Inspect the top bearing in the pivot housing.

Inspect the "O" rings and "V" seal, replace if worn.

It is sometimes easier to remove the Pacific generator head with the pivot in situ. Disconnect the battery first and remove the brushes.

Uncoil the retaining ring and lift the body over the pivot.

The exposed slip-ring must be protected from the environment if the generator is removed for further servicing.

When reassembling put silicone grease (not petroleum grease or jelly) around the shaft where it passes through the lower bearing. Slide the bearing and "V" seal down the shaft about 20mm and wipe grease around the shaft.

Slide the bearing back up the shaft and remove the excess grease, wipe a fillet of grease around the point where the "V" seal sits and slide the "V" seal into place.

Before reinsertion wipe the slip rings to remove any trace of contamination due to handling and put grease around the lower bearing "O" ring. Gently slide into place and wind the spiral retaining ring into its groove.

Clean and replace the brushes. Re-check the pivot for

excess side play, if this is suspect replace the lower bearing and "O" ring. Failure to do so may wear the pivot. If the rectifier cover is removed, **it must be totally resealed** before returning the Pacific to service.

ELECTRICAL SECTION

Note. By far the most common cause of reduced output is corroded wiring between Pacific and battery. Before suspecting the machine, check any screw terminal or crimp connections and all cable runs between Pacific and battery.

Possible faults to consider if reduced output is suspected:-

- a) **Poor wiring connections.** Inspect all the screw terminals in the Pacific circuit for signs of fatigue or corrosion.
- b) **Sticking brushes** or associated brushgear contact problems. See Pivot Section.
- c) **Faulty Rectifiers.** The rectifiers and metal oxide varistor should last the life of the machine. The most likely cause for their demise is accidental reverse polarity connection of Pacific to battery. If this is suspected the rectifier diode bridges must be checked. Reverse polarity connection can also melt the solder on the brush holder spring connections, these can be checked by removing the pivot and looking into the lower body section.

A simple method of checking the machine's output is to disconnect it from the battery and short together its output leads whilst turning the shaft by hand. A marked increase in resistance to turning should be felt as the shorting occurs.

Diode Test. This test will show if the rectifier diodes are either open or short circuit. If your multimeter has a diode check feature, select this (if not select the highest resistance range) and having removed the brush caps and brushes, apply the red meter

lead to the upper brush holder, black lead to lower holder, and note the reading. Now reverse the connections.

*This test is not as conclusive as the Diode Test method however, provided the first reading is a very high resistance and the second reading far lower, then the test is valid. Actual values will depend on the voltage supplied by the particular meter for its resistance ranges.

Multimeter Setting				
Lead Position	Diode Test		Ohms x 100 Range	
Red to upper holder	No Reading	or	Many Megohms*	OK
	Reading	or	Low resistance	US
Black to upper holder	12V (2 diode)	or	Markedly less*	OK
	No Reading	or	High Resistance	US

The rectifiers are located in the small box on the back of the Pacific body. To inspect them remove the four screws and the plate. This has been sealed with polyurethane sealant.

After removing the screws insert a thin blade to cut the seal. The sealant must be renewed on re-assembly after the mating faces have been cleaned.

Failure to do this can cause severe brush gear corrosion in future.

Unsolder the commoning links between the rectifier outputs and check outputs separately. If a new rectifier has to be fitted, unhook the spring connections to the brush holders in the lower body section noting polarity, (Brown wire = positive output = upper brush holder) and unsolder the four stator wires from the rectifiers.

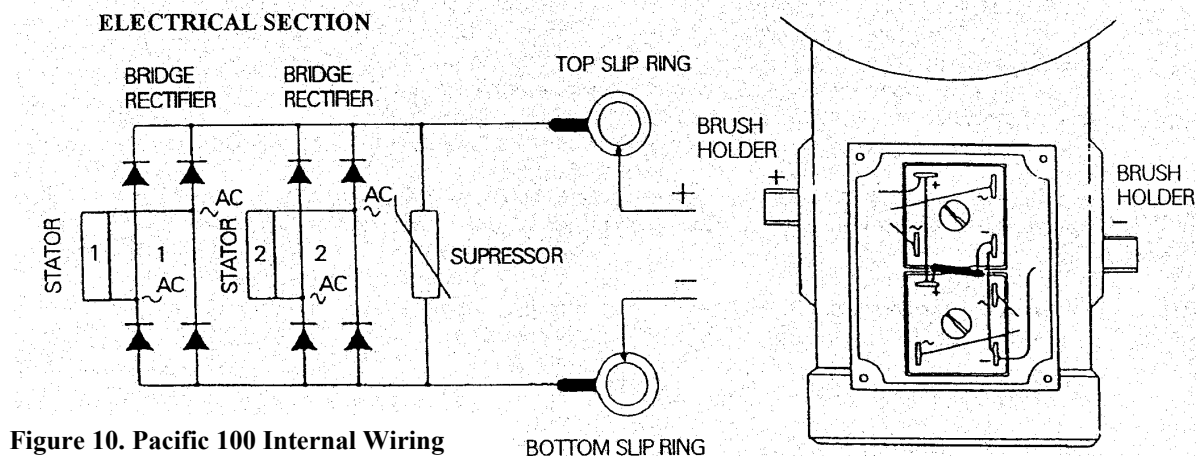

Figure 10. Pacific 100 Internal Wiring

d) Faulty stator. Check AC input to rectifiers or check for coil continuity and isolation from the case. The resistance should be less than two Ohms per 12 volt stator (approx. 4 times this for 24 volt stator)

Note. Do not attempt to modify a 12V machine to 24V. Whilst at first sight this may appear possible by connecting the outputs of the stators in series, greatly reduced output will be encountered since they are not in phase. A 24V machine with 24V windings is available.

ALTERNATOR SECTION

Referring to figure 8, undo the two M8 x 25 screws on the front of the Pacific and pull the nose piece away from the main body. Do this very carefully as it cannot be withdrawn far due to the front stator wiring connection. The shaft and bearings are located using Loctite anaerobic adhesives so some force may be necessary to part them. A puller may have to be improvised to do this. This job should be done on a suitable work bench. The rear bearing needs a bearing puller to remove it, if no puller is available, a dummy shaft may be fixed in the bearing centre using epoxy adhesive and, when cured, the bearing worked loose. The front bearing may be drifted out following removal of the seal and circlip.

Prior to re-assembly, the bearing housings, the bearing inner and outer surfaces and the shaft surfaces should all be thoroughly cleaned and de-greased. When re-assembling use adhesives as follows:-

Stator to body	- Loctite 648
Bearings to body	- Loctite 641
Shaft to bearings	- Loctite 641

When replacing the fore-body, make sure that the "O" ring is in place and well smeared with silicone grease. Assemble the body checking that the wiring to the front stator cannot touch the rotor. Ensure that the timing marks on the body junction line coincide.

If the "cogging" or break out torque has been correctly minimised, 12 minor, equal "lumps" of resistance per revolution will be felt when turning the shaft by hand. This resistance should not exceed 2kg-cm (30oz-in). When doing this make sure that the output leads are not shorted together.

STATOR/ROTOR REPLACEMENT

This is normally a factory operation. Rotor damage is unlikely, but sometimes occurs due to corrosion or other mechanical problems. Considerable force is necessary to break the adhesive bond between the rotor and shaft and a bearing press with guide tools to protect the shaft is needed.

Rotor/shaft assemblies can be returned for replacement.

Stator failure only normally occurs due to salt water immersion. Any accident causing this necessitates the immediate cleaning of all parts with fresh water and then

drying thoroughly. Leaving to dry naturally causes the loss of stator winding insulation due to salt corrosion resulting in electrical leakage and shorted turns.

Stator replacement involves baking in an oven to break adhesive bonds prior to drifting out the old stators, thoroughly cleaning the castings and replacement fitting and wiring. Full workshop facilities are needed for this.

RECOMMENDED SPARES

To cater for the possibility of accidental damage, it is suggested that a spare pair of blades be carried.

Other spares worth considering are:-

Shaft seal -	Replacement may be required after 1 - 2 years use.
Pivot seal -	Replacement may be required after several years.
Pivot lower bearing-	Replacement may be required after several years.
Brush set -	In case of loss during servicing.
2 bearings -	Unlikely to be required but an insurance policy
Rectifier assembly -	Unlikely to be required unless polarity is accidentally reversed, however, another insurance policy.

WARRANTY

The Ampair Pacific 100 is warranted for one year from the date of purchase.

Any faulty part will be replaced free of charge and any faulty workmanship will be rectified free of charge upon prepaid return of a unit to Ampair or any authorised agents. The unit will then be returned to the customer free of charge.

This warranty does not cover mishandling, accidental damage or faulty installation. Nor can Ampair or its authorised agents be liable for any consequential damage.

Ampair will, nevertheless, go to considerable lengths to ensure customer satisfaction and fully appreciate the problems of those in far away places.

SERVICING & REPAIRS

Ampair Pacific 100's may be returned to: -

AMPAIR

Park Farm, Warfield, Berkshire RG42 5RH, UK
Tel: +44 (0)845 389 0660 Fax: +44 (0)1344 303 312
e-mail service@ampair.com www.ampair.com

© This Manual is the Copyright of Ampair Jan. 2001