

AEROGEN REGULATION AND MOUNTING



Battery Charging and Protection- Voltage Regulators (TB Units)

Voltage regulators and diode units are available for single, twin and triple independent battery protection. When the batteries reach full charge the power produced by the generator is diverted to a wire wound resistor and dissipated as heat thus ensuring the generator is "on load" at all times.

Twin Battery Regulators (TB Units) are unaffected by other charging sources i.e. engine alternators and shore power; therefore it is recommended that they are used in marine applications and makes them ideal for separate charging of engine and domestic batteries.

They incorporate:

- Voltage monitoring/PMW circuit.
- Power Mosfet.
- Schottky Diodes.

To regulate three independent batteries add a diode unit (DU Unit). Typical wiring diagrams can be found on our web site at: www.lvm-ltd.com/regulators.htm

Easy Installation- Mounting Kits

A range of marine grade 316 stainless steel mounting kits are available from LVM for simple and rapid installation.

LVM K1- Bracket fixing to pushpit and 0.5 metre of 1in. o.d. tube.

LVM K2- 1.2 metre of 1in. o.d. tube: 1in. stanchion mount: universal plate to fix 1in. mounting tube to 1in. pushpit tube.

LVM K3- Offset 1.2 metre of 1in. o.d. tube: 1in. stanchion mount: universal plate to fix 1in. mounting tube to 1in. pushpit tube. (Offsets Aero2gen completely) **NOTE THIS KIT IS ONLY SUITABLE FOR THE AERO2GEN.**

LVM K4- 1.45 metre of 1.5in. o.d. tube: 1.5in. stanchion mount: universal plate to fix 1.5in. mounting tube to 1in. pushpit tube.

LVM K5- 2.9 metre x 1.5in. o.d. tube; 1.5in. stanchion mount: universal plate to fix 1.5in. mounting tube to 1in. pushpit tube: 4mm wire stays and fixings.

Universal Mounting Plates-

LVM 163 - To fix 1in. o.d. tube to 1in. o.d. tube.

LVM 168 - To fix 1in. o.d. tube to 1.5in. o.d. tube.

Mounting Kit Choice

	Aero2gen	Aero4gen	Aero6gen
LVM	K1	-	K4
LVM	K2	K2	K5
LVM	K3	K4	-

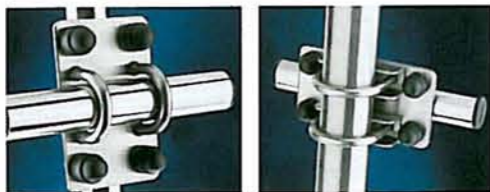

AEROGEN SPECIFICATIONS

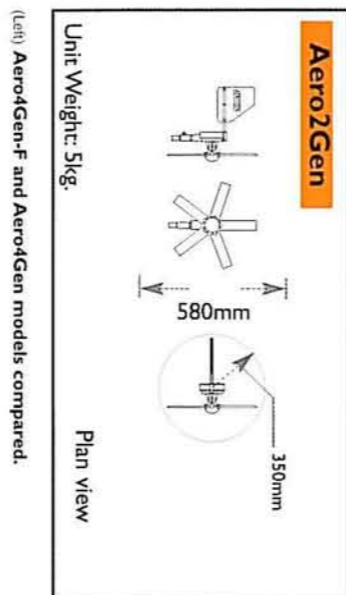

(Left) Aero4Gen-F and Aero4Gen models compared.

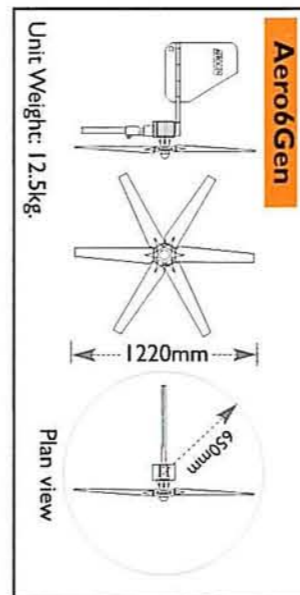
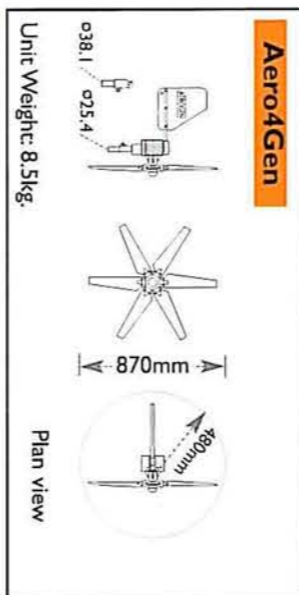
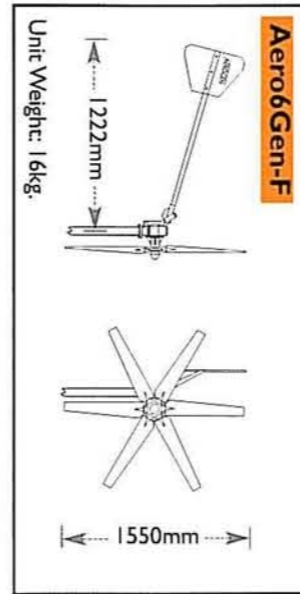
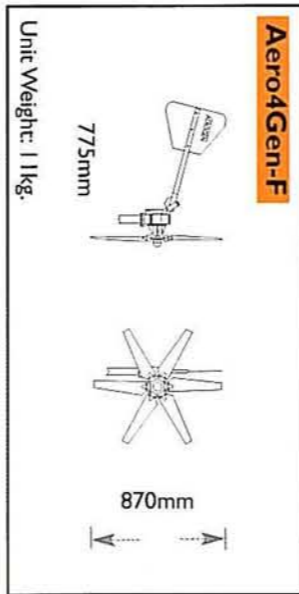

LVM Limited, AeroGen House, Old Oak Close, Arlesey, Bedfordshire SG15 6XD
Telephone: +44 (0) 1462 733336 Facsimile: +44 (0) 1462 730466
e-mail lvm.ltd@dial.pipex.com Visit us at www.lvm-ltd.com



AEROGEN WIND GENERATORS

Available Worldwide From Distributors and Retailers





AEROGEN MARINE WIND GENERATORS

Aerogen marine wind generators are ideal for charging lead acid and gel batteries when mains power is either not available or not suitable. Once purchased the power produced is FREE and the uses are many on land and sea, both for regular and emergency use. The models available cover the needs of weekend, cruising and live-aboard yachtsmen. The **Aerogens** detailed in this brochure are 'Third Generation'. They feature the latest technology and the expertise and experience we have gained since 1982, manufacturing wind generators and supplying them worldwide for land and sea use.

In choosing your **Aerogen** the key parameters are Aerogen outputs, power requirements and wind speeds. Aerogen outputs are tabulated in table 1. Most equipment will detail power draw and therefore estimates can be made of power usage. In most parts of the world windspeeds average 8 -20 knots. Around the averages the wind is volatile and gales and calm periods occur with varying frequencies depending on the season. Data is available from meteorological authorities world-wide.

Aero2gen- The ideal small wind generator for weekend yachtsmen, small yachts and low power land applications. Weighing only 5 kilos the design can ensure that batteries are maintained and fully charged for each visit and make a contribution whilst sailing/caravaning. The Aero2gen produces 0.5 amps at 12 knots and 1.0 amp at 19 knots. It can produce 1.5

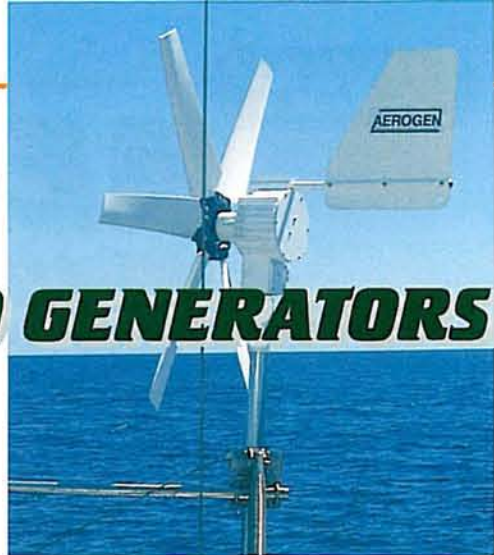

amps continuously at 22 knots. It operates safely but not continuously in gales and can produce a maximum of 4 amps intermittently. The Aero2gen is thermally protected. (Mounting for 1" tube only).

Aero4gen- Produces more power for the cruising yachtsmen and static and mobile caravans. It can provide sufficient power for cruising yachts with significant electrical equipment, even refrigeration. The Aero4gen produces 2 amps at 13 knots and 6amps at 20 knots. It operates safely and continuously in storms and can produce a maximum 19 amps continuously in 60 knot winds. The Aero4gen is self limiting. (Mounting for 1" or 1 1/2" tube).

Aero6gen- The powerful Aero6gen is the ideal unit for the live aboard yachtsmen and applications with high power usage. The Aero6gen produces 4 amps at 12 knots and 10 amps at 20 knots. The Aero6gen is optimised to maintain continuous high outputs in higher wind speeds. It operates safely and continuously in 45 knot winds, producing 30 amps. Above 45 knots it requires a certain degree of manual control and is therefore not suitable for unattended applications. (Mounting for 1 1/2" tube).

The performances of all Aerogens have been established by independent testing.



Powerful Performance

The optimum wind speed is between 5 and 20 knots. Aerogens are designed to operate efficiently in this range, starting to charge at 5 knots. Equally they take advantage of higher wind speeds to produce higher outputs continuously and safely.

Amps Output @ 12-14v Against Wind Speed (knots)

Amps	Aero2gen	Aero4gen	Aero6gen	Aero4gen F ₊ (Furled)	Aero6gen F ₊ (Furled)
30	-	-	45	-	-
20	-	60	30	-	40
15	-	40	23	-	25
10	-	28	20	40	20
8	-	25	17	33	17
6	-	20	15	23	15
5	-	19	14	20	14
4	40	17	12	18	12
3	33	15	11	15	11
2	25	13	10	13	10
1	19	10	7.5	10	7.5
0.5	12	8	6.5	8	6.5

Table 1

Wind Speed (Knots)
All figures approx. Cut in speed 5 knots

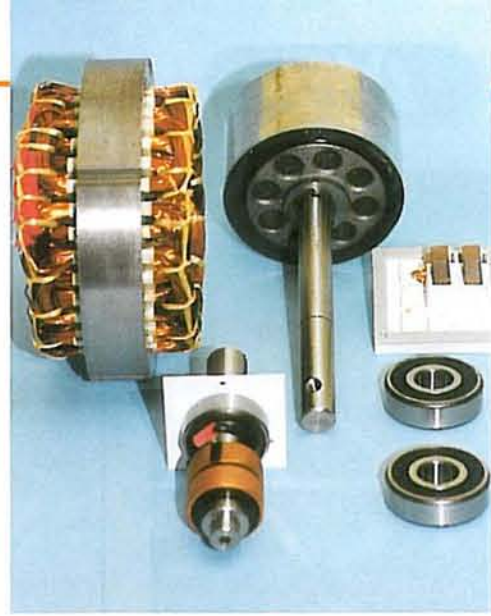

Quiet: Safe: Low Speed Efficient Propellers

LVM computer designed aerofoil section blades are used to maximise the generators output at comparatively low wind speeds therefore ensuring enhanced safety, comfort and bearing wear.

High Efficiency Brushless Alternators

- High efficiency hand wound 3 phase brushless alternators.
- Neodymium Iron Boron permanent magnet rotor; sleeved and epoxy potted.

Compact: Light: Robust: and Maintenance Free

Aerogens are lighter and smaller than some units with similar or even lower performances.

- They are sturdy and robust.
- Incorporate heavy duty bearings, slip-rings and brushes.
- Corrosion resistant marinated materials are used throughout.

All **Aerogens** provide years of maintenance free use, and are available in both 12 and 24 volt.



AEROGEN FURLED INLAND GENERATORS

Aerogen inland furling wind generators are designed for unattended applications. They will produce approximately the same output as their marine equivalent, but are automatically furled at wind speeds above 40 knots by the special pivoting tail assembly, which turns the generator side ways to the wind thus limiting its output and protecting the generator.

There are two models available:

Aero4gen-F and Aero6gen-F

They incorporate many of the same components as the marine models and operate continuously and safely in storm force winds. With the introduction of stainless steel tail fin and tube they are ideal for coastal inland sites. Furling generators have been used successfully throughout the world in some of the most remote and extreme weather locations, often used in combination with solar panels. Some typical applications include:

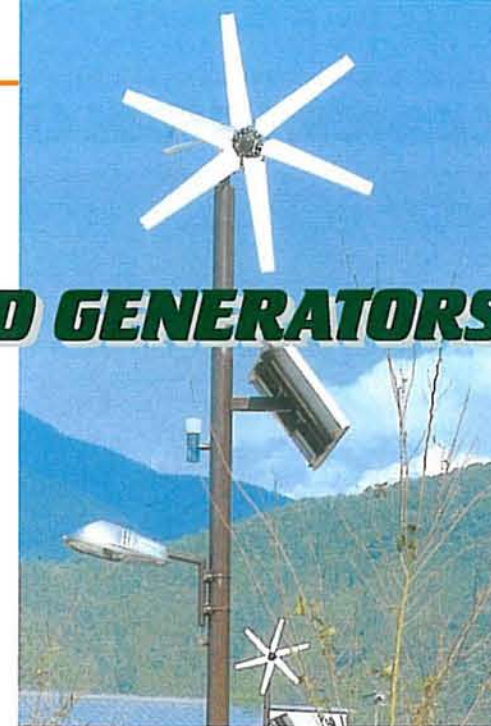

Street lighting, Remote telemetry, Data loggers and Electric fencing.

Mounting- They have a flange to flange-mounted arrangement. A flange is supplied with the generator; which must be welded to the top of a 2-inch diameter tube or scaffold pipe, the generator is then simply bolted to this flange.

They ARE NOT suitable for use on yachts.

Application	Power Use Weekly Amp Hours 12 volt dc	Aerogen Choice	Power Generated Amp Hours Weekly 12 volt dc @ 12 Knots
Weekend Yachtsmen/Caravaners	20 - 75	Aero2gen	85
Cruising Yachtsmen/Caravaners	70 - 300	Aero4gen	300
Live aboard Yachtsmen Caravaners/Summer Houses	300 - 650	Aero6gen	670
Telemetry/Remote Extreme Conditions	100 - 300 300 - 650	Aero4gen-F Aero6gen-F	300* 670*
Summer/Remote Houses Alternative Lifestyle Possible Extreme Conditions	300 - 650	Aero6gen-F	670*

Table 2

* In winter in these locations wind speeds can average over 25 knots with frequent gales.